

REVISIONS			
REV.	DESCRIPTION	ECN	DATE
A.0	1. CREATED DRAWING.		7/6/2011
A.1	1. ADDED DRAIN PLUG NOTE AND DUAL DIMENSIONS		7/15/2011
A.2	1. CHANGED STAINER TO STRAINER IN TITLE BLOCK.		7/23/2013

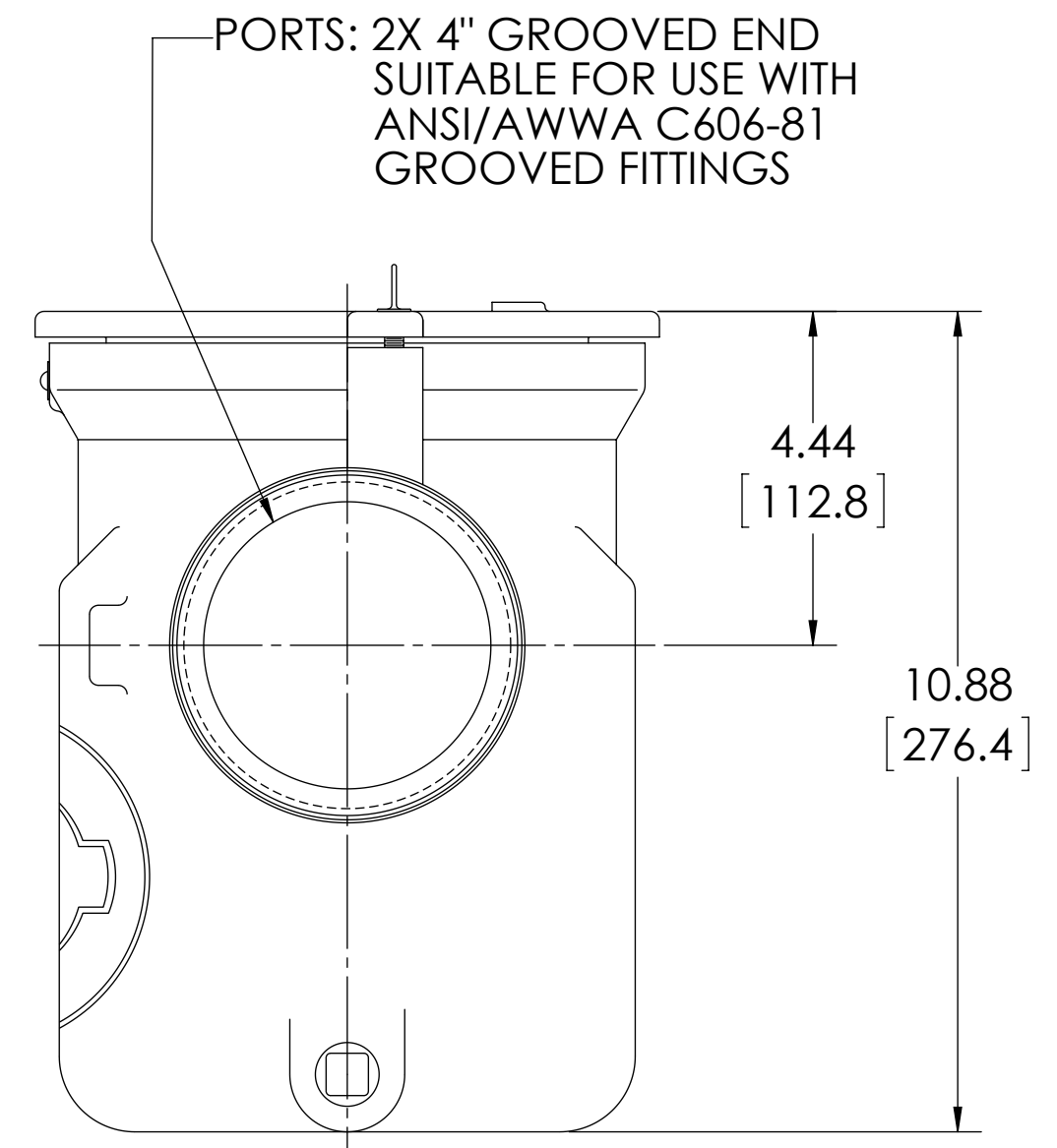
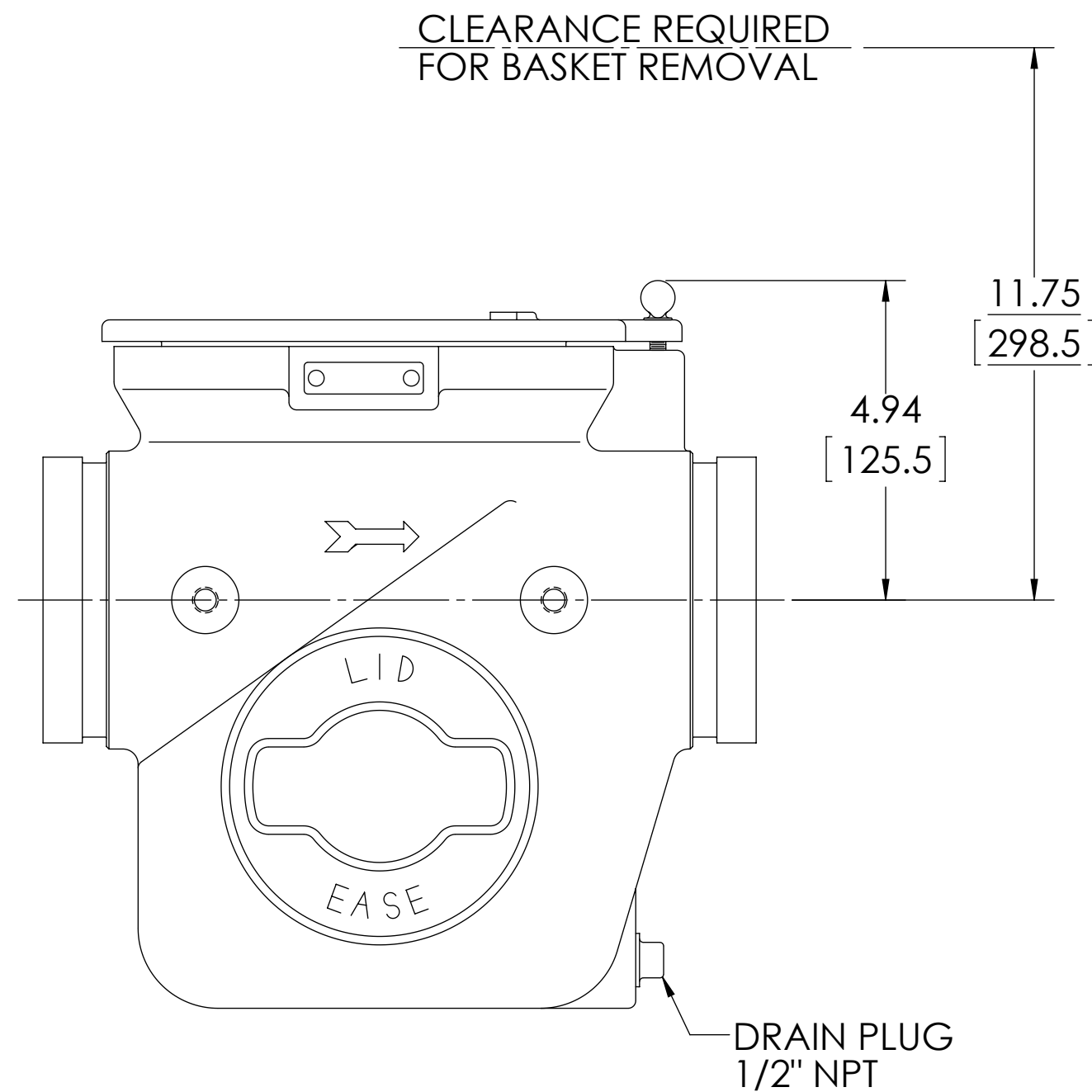

NOTES:  
 1. REFER TO VIKING CATALOG SECTION 640 FOR -XXX MODEL NUMBER CLARIFICATION.

MESH	10	20	40	60	80	100	USE AND RELATED INFORMATION
OPENING (INCHES)	.075	.034	.015	.0092	.007	.0055	
OPENING (MICRONS)	1910	860	380	230	190	140	

MATERIAL:  
 WAS:

UNLESS OTHERWISE SPECIFIED DIMENSIONS ARE IN **INCHES**.  
 INTERPRET DIM AND TOLERANCES PER VIKING PUMP ES-47  
 BREAK EDGES .005-.015 RADIUS OR CHAMFER  
 .XX ±.02 .XXX ±.005 ANGLES ±5°  
 ALL FINISHED SURFACES  $\nabla_{250}$  (AA .030 CUTOFF)  
 ACCEPTABILITY OF SCREW THREADS SHALL BE DETERMINED BASED ON SYSTEM 21 ASME B1.3  
 THIRD ANGLE PROJECTION

STATE	Released	07/26/2013
DRAWN	rmennenga	7/6/2011
CHECKED	BAM	07/25/2013
PROJECT	2D	WEIGHT: LBS
SCALE: 2:5		
CASTING NUMBER		

**VIKING PUMP**  
 VIKING PUMP, INC.  
 A Unit of IDEX Corporation  
 Cedar Falls, IA 50613  
 U.S.A.

THIS DRAWING IS THE PROPERTY OF VIKING PUMP, INC. AND IS PROPRIETARY IN GENERAL AND DETAIL. IT SHALL NOT BE COPIED OR ITS CONTENTS REVEALED TO OUTSIDE PARTIES WITHOUT THE WRITTEN CONSENT OF VIKING PUMP, INC.

STRAINER ASSEMBLY, 4" GROOVED ENDS - MODELS F-1040-GSST-XXX, F-1040-GALM-XXX

(A.2)

SIZE **C** DWG. NO. **F-1040-G** SHEET 1 OF 1 REV **A.2**