



TECHNICAL SERVICE MANUAL

ABRASIVE LIQUID HEAVY-DUTY BRACKET MOUNTED PUMPS SERIES 4625 SIZES H - M

SECTION	TSM 410.2
PAGE	1 OF 10
ISSUE	D

CONTENTS

Introduction	1
Special Information	3
Maintenance	3
Disassembly	5
Assembly	6
Thrust Bearing Adjustment	8
Pressure Relief Valve Instructions	9

INTRODUCTION

The illustrations used in this manual are for identification purposes only and cannot be used for ordering parts. Obtain a parts list from the factory or a Viking representative. Always give complete name of part, part number and material with model number and serial number of pump when ordering repair parts. The unmounted pump or pump unit model number and serial number are on the nameplate.

In the Viking model number system, basic size letters are combined with series number 4625 indicating both unmounted or mounted pump unit.



FIGURE 1 - SIZES H AND HL

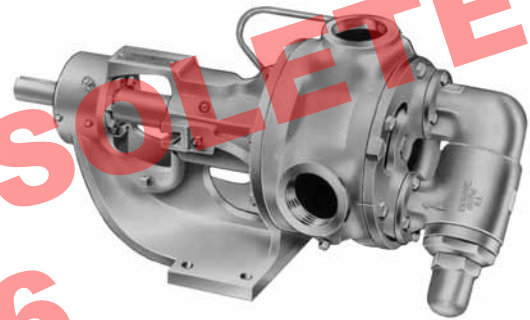

FIGURE 2 - SIZES K, KK AND L

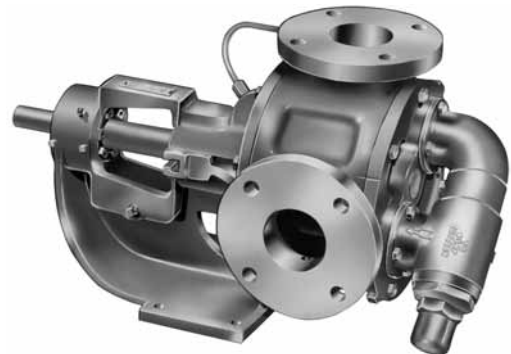

FIGURE 3 - SIZES LQ AND LL



FIGURE 4 - SIZES Q AND M

UNMOUNTED PUMP	UNITS
MECH. SEAL	
H4625	Units are designated by the unmounted pump model numbers followed by a letter indicating drive style.
HL4625	
K4625	
KK4625	
L4625	
LQ4625	V = V-Belt
LL4625	D = Direct Connected
Q4625	R = Viking Speed Reducer
M4625	P = Commercial Speed Reducer

This manual deals only with Series 4625 Abrasive Liquid Heavy-Duty Bracket Mounted Pumps. Refer to Figures 1 through 14 for general configuration and nomenclature used in this manual. Pump specifications and recommendations are listed in Catalog Section 410, Series 4625 Abrasive Liquid Heavy-Duty Bracket Mounted Pumps.

SAFETY INFORMATION AND INSTRUCTIONS

IMPROPER INSTALLATION, OPERATION OR MAINTENANCE OF PUMP MAY CAUSE SERIOUS INJURY OR DEATH AND/OR RESULT IN DAMAGE TO PUMP AND/OR OTHER EQUIPMENT. VIKING'S WARRANTY DOES NOT COVER FAILURE DUE TO IMPROPER INSTALLATION, OPERATION OR MAINTENANCE.

THIS INFORMATION MUST BE FULLY READ BEFORE BEGINNING INSTALLATION, OPERATION OR MAINTENANCE OF PUMP AND MUST BE KEPT WITH PUMP. PUMP MUST BE INSTALLED, OPERATED AND MAINTAINED ONLY BY SUITABLY TRAINED AND QUALIFIED PERSONS.

THE FOLLOWING SAFETY INSTRUCTIONS MUST BE FOLLOWED AND ADHERED TO AT ALL TIMES.

Symbol Legend :



Danger - Failure to follow the indicated instruction may result in serious injury or death.

WARNING

Warning - In addition to possible serious injury or death, failure to follow the indicated instruction may cause damage to pump and/or other equipment.



BEFORE opening any liquid chamber (pumping chamber, reservoir, relief valve adjusting cap fitting, etc.) be sure that :

- Any pressure in the chamber has been completely vented through the suction or discharge lines or other appropriate openings or connections.
- The pump drive system means (motor, turbine, engine, etc.) has been "locked out" or otherwise been made non-operational so that it cannot be started while work is being done on the pump.
- You know what material the pump has been handling, have obtained a material safety data sheet (MSDS) for the material, and understand and follow all precautions appropriate for the safe handling of the material.

WARNING

INSTALL pressure gauges/sensors next to the pump suction and discharge connections to monitor pressures.



WARNING

USE extreme caution when lifting the pump. Suitable lifting devices should be used when appropriate. Lifting eyes installed on the pump must be used **only** to lift the pump, **not** the pump with drive and/or base plate. If the pump is mounted on a base plate, the base plate must be used for all lifting purposes. If slings are used for lifting, they must be safely and securely attached. For weight of the pump alone (which does not include the drive and/or base plate) refer to the Viking Pump product catalog.



BEFORE operating the pump, be sure all drive guards are in place.



DO NOT attempt to dismantle a pressure relief valve that has not had the spring pressure relieved or is mounted on a pump that is operating.



DO NOT operate pump if the suction or discharge piping is not connected.



AVOID contact with hot areas of the pump and/or drive. Certain operating conditions, temperature control devices (jackets, heat-tracing, etc.), improper installation, improper operation, and improper maintenance can all cause high temperatures on the pump and/or drive.



DO NOT place fingers into the pumping chamber or its connection ports or into any part of the drive train if there is **any possibility** of the pump shafts being rotated.



THE PUMP must be provided with pressure protection. This may be provided through a relief valve mounted directly on the pump, an in-line pressure relief valve, a torque limiting device, or a rupture disk. If pump rotation may be reversed during operation, pressure protection must be provided on **both** sides of pump. Relief valve adjusting screw caps must always point towards suction side of the pump. If pump rotation is reversed, position of the relief valve must be changed. Pressure relief valves cannot be used to control pump flow or regulate discharge pressure. For additional information, refer to Viking Pump's Technical Service Manual TSM 000 and Engineering Service Bulletin ESB-31.

WARNING



DO NOT exceed the pumps rated pressure, speed, and temperature, or change the system/duty parameters from those the pump was originally supplied, without confirming its suitability for the new service.

WARNING



WARNING

BEFORE operating the pump, be sure that:

- It is clean and free from debris
- all valves in the suction and discharge pipelines are fully opened.
- All piping connected to the pump is fully supported and correctly aligned with the pump.
- Pump rotation is correct for the desired direction of flow.



WARNING

THE PUMP must be installed in a matter that allows safe access for routine maintenance and for inspection during operation to check for leakage and monitor pump operation.

SPECIAL INFORMATION

DANGER !

Before opening any Viking pump liquid chamber (pumping chamber, reservoir, relief valve adjusting cap fitting, etc.) Be sure:

1. That any pressure in the chamber has been completely vented through the suction or discharge lines or other appropriate openings or connections.
2. That the driving means (motor, turbine, engine, etc.) has been "locked out" or made non-operational so that it cannot be started while work is being done on pump.
3. That you know what liquid the pump has been handling and the precautions necessary to safely handle the liquid. Obtain a material safety data sheet (MSDS) for the liquid to be sure these precautions are understood.

Failure to follow above listed precautionary measures may result in serious injury or death.

ROTATION: Viking pumps operate equally well in a clockwise or counter-clockwise rotation. Shaft rotation determines which port is suction and which is discharge. Port in area where pumping elements (gear teeth) come out of mesh is suction port.

PRESSURE RELIEF VALVES:

1. Viking pumps are positive displacement pumps and must be provided with some sort of pressure protection. This may be a relief valve mounted directly on the pump, an inline pressure relief valve, a torque limiting device or a rupture disk.
2. There are relief valve options available on those pump models designed to accept a relief valve. Options may include a return to tank relief valve and a jacketed relief valve. Pumps equipped with a jacketed head plate are generally not available with a relief valve.
3. If pump rotation is to be reversed during operation, pressure protection must be provided on both sides of pump.
4. Relief valve adjusting screw cap must always point towards suction side of pump. If pump rotation is reversed, remove pressure relief valve and turn end for end. Refer to Figures 1 and 2, page 1.

5. Pressure relief valves cannot be used to control pump flow or regulate discharge pressure.

For additional information on pressure relief valves, Refer to Technical Service Manual TSM000 and Engineering Service Bulletin ESB-31.

SPECIAL MECHANICAL SEALS:

Extra care should be taken in repair of these pumps. Be sure to read and follow all special instructions supplied with your pump.

MAINTENANCE

Series 4625 pumps are designed for long, trouble-free service life under a wide variety of application conditions with a minimum of maintenance. The points listed below will help provide long service life.

LUBRICATION: External lubrication must be applied slowly with a handgun to all lubrication fittings every 500 hours of operation with multi-purpose grease, NLGI # 2. Do not over-grease. Applications involving very high or low temperatures will require other types of lubrication. Refer to Engineering Service Bulletin ESB-515. Consult factory with specific lubrication questions.

CLEANING PUMP: Keep pump as clean as possible. This will facilitate inspection; adjustment and repair work and help prevent overlooking a dirt covered grease fitting.

STORAGE: If pump is to be stored, or not used for six months or more, pump must be drained and a light coat of non-detergent SAE 30 weight oil must be applied to all internal pump parts. Lubricate fittings and apply grease to pump shaft extension. Viking suggests rotating pump shaft by hand one complete revolution every 30 days to circulate the oil.

SUGGESTED REPAIR TOOLS: The following tools must be available to properly repair Series 4625 pumps. These are in addition to standard mechanics' tools such as open end wrenches, pliers, screwdrivers etc. Most of the items can be obtained from an industrial supply house.

1. Soft Headed Hammer
2. Mechanical seal installation sleeve
2-751-002-900 for 1.125 inch seal; H & HL 4625
2-751-003-900 for 1.4375 inch seal; K & LL 4625
2-751-005-630 for 2.4375 inch seal; Q and M4625
3. Bearing locknut spanner wrench
(Source: #471 J.H. Williams & Co. or equal)
4. Spanner wrench, adjustable pin type for use on double end caps (Source #482 J.H. Williams & Co or equal)
5. Brass Bar
6. Arbor Press
7. Standard 5/16" 12 point socket

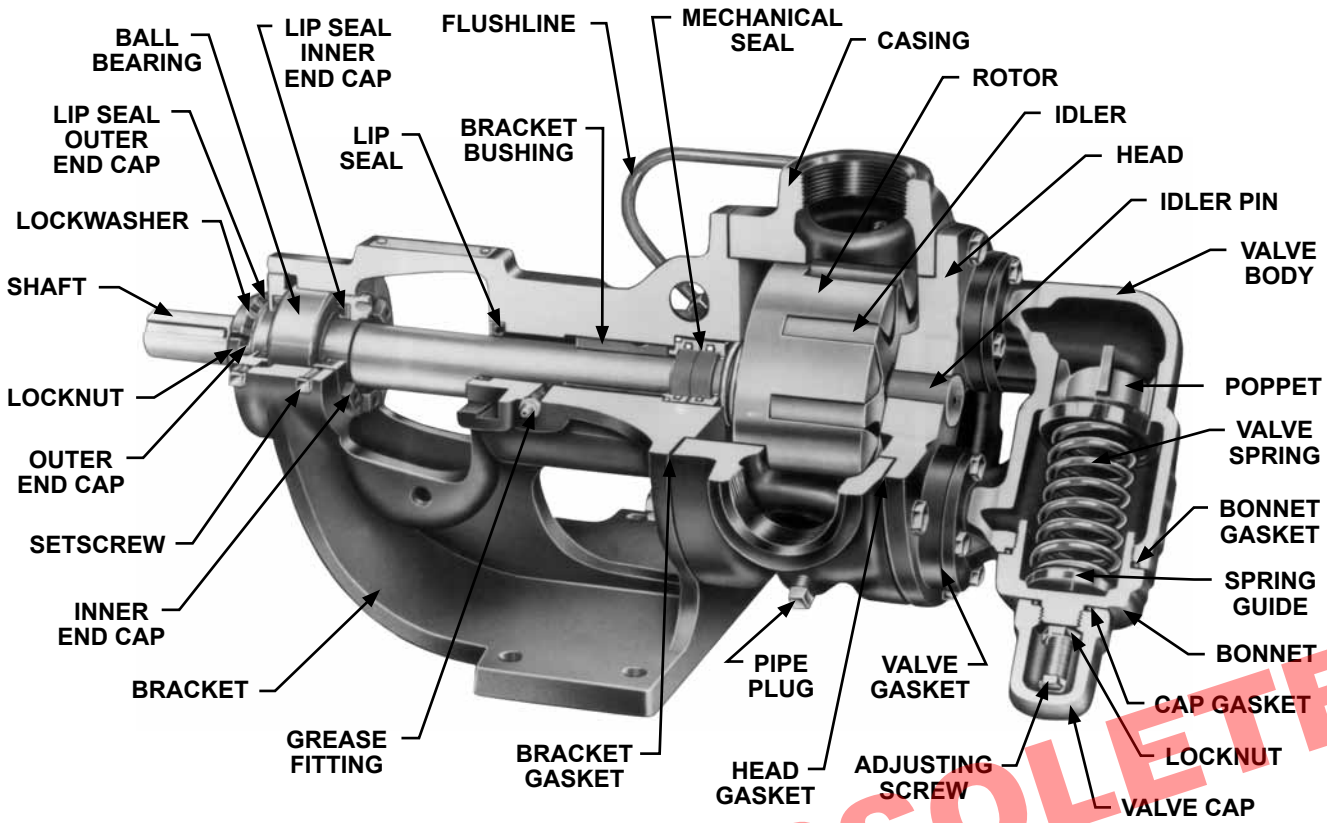
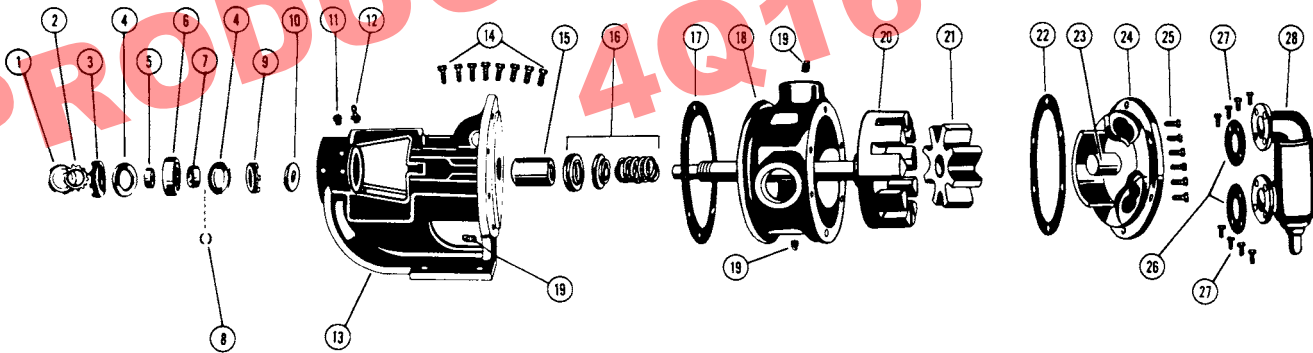
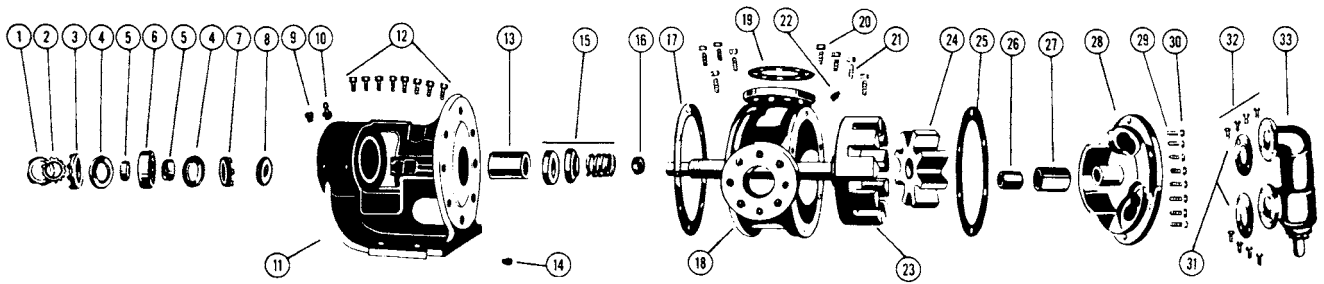

FIGURE 5
CUTAWAY VIEW OF KK4625 WITH CALLOUTS



EXPLODED VIEW FOR MODELS H4625, HL4625, K4625, KK4625, L4625, LQ4625 AND LL4625
(MODEL KK4625 SHOWN)

ITEM	NAME OF PART	ITEM	NAME OF PART	ITEM	NAME OF PART
1	Locknut	11	Pressure Relief Plug	21	Idler and Bushing
2	Lockwasher	12	Grease Fitting	22	Head Gasket
3	End Cap (Outer)	13	Bracket and Bushing	23	Idler Pin
4	Lip Seal for End Cap	14	Capscrew for Bracket	24	Head and Idler Pin
5	Bearing Spacer Collar (Outer)	15	Bracket Bushing	25	Capscrew for Head
6	Ball Bearing	16	Mechanical Seal	26	Relief Valve Gasket
7	Bearing Spacer Collar (Inner)	17	Bracket Gasket	27	Capscrew for Valve
8	Ring, Half Round (K-LL)	18	Casing	28	Internal Relief Valve
9	End Cap (Inner)	19	Pipe Plug		
10	Lip Seal for Seal Chamber	20	Rotor and Shaft		



EXPLODED VIEW FOR MODELS Q4625 AND M4625 (M4625 SHOWN)

ITEM	NAME OF PART	ITEM	NAME OF PART	ITEM	NAME OF PART
1	Locknut	13	Bracket Bushing	25	Head Gasket
2	Lockwasher	14	Pipe Plug	26	Idler Pin Sleeve & Self Lock Pin
3	End Cap (Outer)	15	Mechanical Seal	27	Idler Pin Sleeve
4	Lip Seal for End Cap	16	Spring Washer (M Only)	28	Head, Pin and Sleeve
5	Bearing Spacer Collar	17	Bracket Gasket	29	Stud for Head
6	Ball Bearing	18	Casing	30	Nut for Head
7	End Cap (Inner)	19	Pipe Flange Gasket	31	Relief Valve Gasket
8	Lip Seal for Seal Chamber	20	Nut for Flanges	32	Capscrew for Valve
9	Pressure Relief Plug	21	Stud for Flanges	33	Internal Relief Valve
10	Grease Fitting	22	Pipe Plug		Flush Line (not illustrated)
11	Bracket and Bushing	23	Rotor and Shaft		
12	Capscrew for Bracket	24	Idler and Bushing		

DISASSEMBLY

DANGER !

Before opening any Viking pump liquid chamber (pumping chamber, reservoir, relief valve adjusting cap fitting, etc.) Be sure:

1. That any pressure in the chamber has been completely vented through the suction or discharge lines or other appropriate openings or connections.
2. That the driving means (motor, turbine, engine, etc.) has been "locked out" or made non-operational so that it cannot be started while work is being done on pump.
3. That you know what liquid the pump has been handling and the precautions necessary to safely handle the liquid. Obtain a material safety data sheet (MSDS) for the liquid to be sure these precautions are understood.

Failure to follow above listed precautionary measures may result in serious injury or death.

1. Mark head and casing before disassembly to insure proper reassembly. The idler pin, which is offset in pump head, must be positioned toward and equal distance between port connections to allow for proper flow of liquid through pump.

Remove head from pump. **Do not allow idler to fall from idler pin.** Tilt top of head back when removing to prevent this. Avoid damaging head gasket. If pump is furnished with pressure relief valve, it need not be removed from head or disassembled at this point. **Refer to Pressure Relief Valve Instructions, page 9.**

If pump has jacketed head plate, it will separate from head when it is removed. The gasket between head and jacket head plate must be totally removed. Use new gasket when assembling pump.

2. Remove idler and bushing assembly.
3. Insert length of hardwood or brass through port opening between rotor teeth to keep shaft from turning. Bend up tang of lockwasher and with a spanner wrench remove locknut and lockwasher from shaft.
4. Tap shaft forward approximately 0.50 inch and remove pair of half round rings under inner bearing spacer collar. There is no pair of half round rings on H, HL, Q and M size pumps.
5. Carefully remove rotor and shaft to avoid damaging bracket bushing.
6. Remove rotary member of seal from shaft and stationary seal seat from bracket.

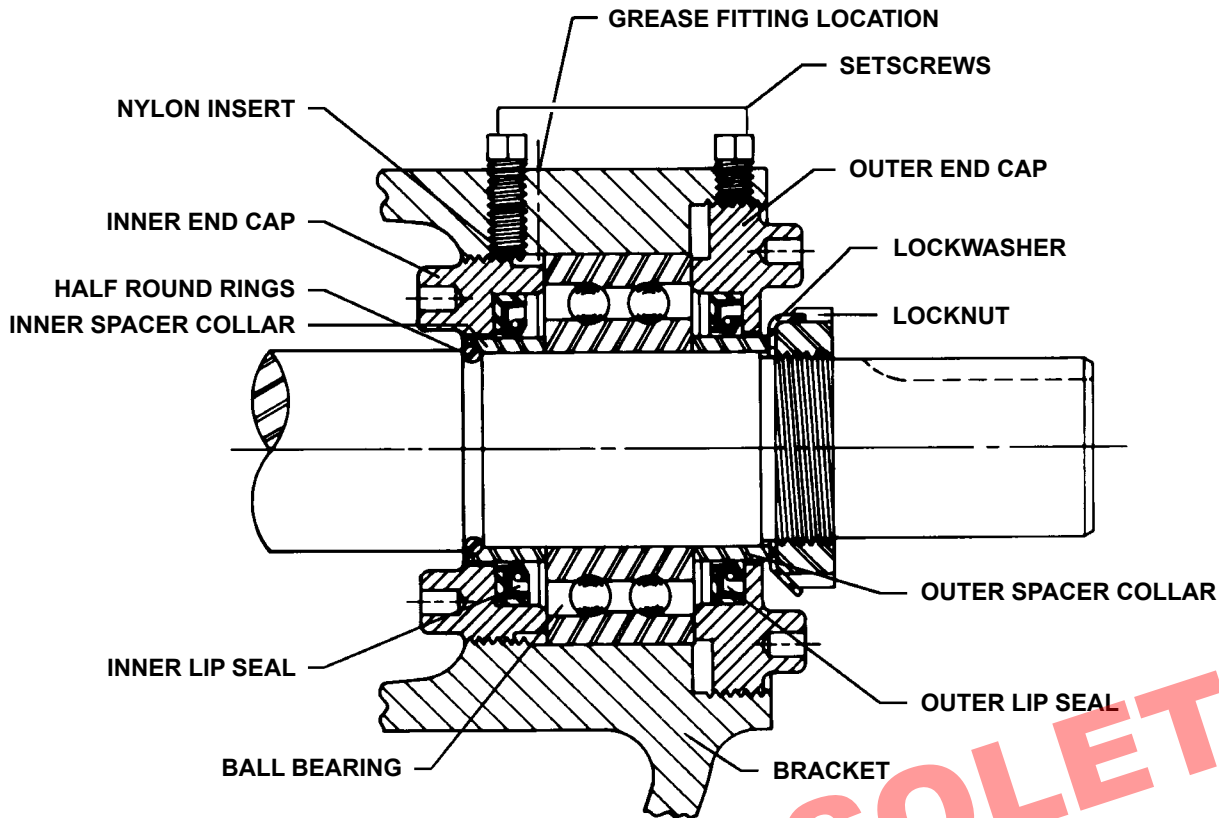

FIGURE 6

7. Loosen setscrews. Two for G, H and HL size pumps, four for all other sizes. With spanner wrench, remove both end caps and lip seals. Remove ball bearing and spacer collars. Refer to Figure 6.
8. Examine seal chamber lip seal and remove if it shows wear or damage. Lip seal must be removed if bracket bushing needs to be replaced.
9. Clean all parts thoroughly and examine for wear or damage. Check lip seals, ball bearing, bushing and idler pin and replace if necessary. It is often possible to reuse the idler pin rather than replace it. Note position of the worn area at least 0.33 turn from previous position. Check all other parts for nicks, burrs, excessive wear and replace if necessary.

Wash bearings in clean solvent. Blow out bearings with compressed air. Do not allow bearings to spin; turn them slowly by hand. Spinning bearings will damage race and balls. Make sure bearings are clean, then lubricate with non-detergent SAE 30-weight oil and check for roughness. Roughness can be determined by turning outer race by hand. If bearings have roughness, replace bearings.

10. Casing can be checked for wear or damage while mounted on bracket.
11. Check flush line to be sure it is open. A long wire may be used to do this. Clean or replace if it is clogged.

ASSEMBLY

Mechanical Seal – (Silicon Carbide with Viton Elastomer)

The seal used in this pump is simple to install and good performance will result if care is taken during installation. Seal faces are made from silicon carbide which is extremely hard and brittle. Do not drop these parts or otherwise mishandle as the faces can chip easily.

The principle of the mechanical seal is contact between the rotary and stationary members. These parts are lapped to a high finish and their sealing effectiveness depends on complete contact.

1. Install bracket bushing. If bracket bushing has a lubrication groove, install bushing with groove at 6.00 o'clock position in bracket.
2. Install lip seal in bracket. Refer to Figure 7.

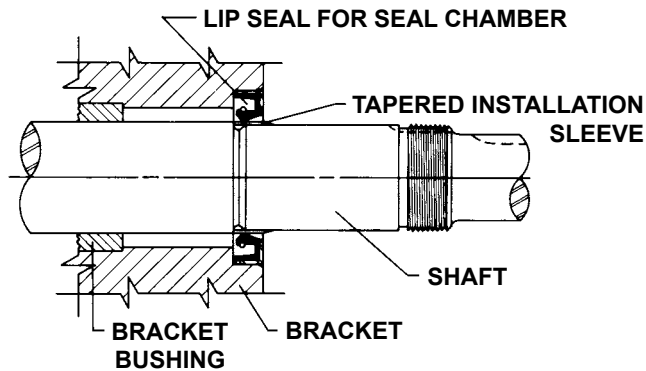

FIGURE 7

Prior to installing rotating portion of mechanical seal, prepare and organize rotor shaft, head and idler assemblies and appropriate gaskets for quick assembly.

Never touch sealing faces with anything except clean hands or clean cloth. Minute particles can scratch the seal faces and cause leakage.

3. Coat idler pin with non-detergent SAE 30 weight oil and place idler and bushing on idler pin in head.
4. Clean rotor hub and bracket seal housing bore. Make sure both are free from dirt and grit. Coat outer diameter of seal seat and inner diameter of seal housing bore with non-detergent SAE 30 weight oil.
5. Install seal seat in seal housing bore, Refer to Figure 8. Make sure drive pins are located in slots in bracket bushing.
6. Place tapered installation sleeve on shaft, Refer to Figure 9. Sleeve is furnished with H, HL, K, KK, L, LQ and LL size replacement mechanical seals. Sleeve for Q and M size pumps may be purchased from Viking Pump at additional cost. Coat rotor shaft, tapered installation sleeve and inner diameter of mechanical seal rotary member with a generous amount of non-detergent SAE 30 weight oil. Petrolatum may be used but grease is not recommended.

NOTE: PTFE fitted seals come with installation sleeve inside the rotary member. **DO NOT** remove this sleeve. Coat shaft with oil and proceed with step 7.

7. Place seal spring on shaft against rotor hub. Refer to Figure 10.

NOTE: Model M4625 uses a seal spring washer. Install washer against rotor hub and then install seal spring.

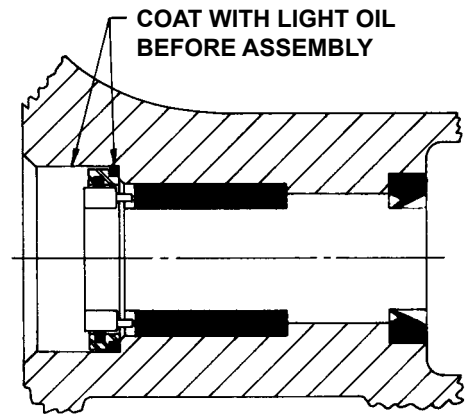

FIGURE 8

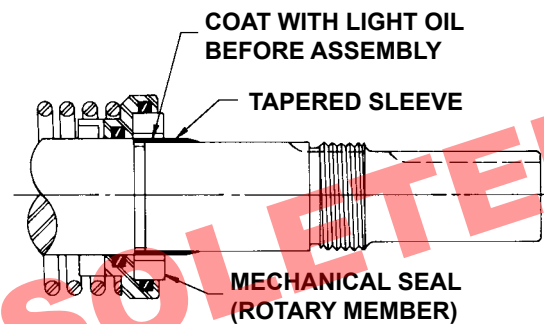

FIGURE 9

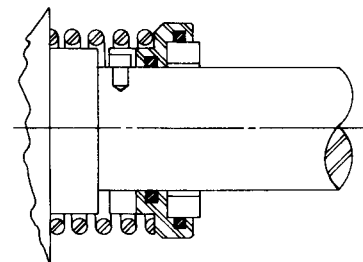

FIGURE 10

8. Slide rotary member, lapped contact surface facing away from spring, over installation sleeve on shaft until it is against spring. Slot in the seal must line up with drive pin shaft.

NOTE: For PTFE seals the rotary member and installation sleeve go on together.

Do not compress spring.

Flush sealing faces of both rotary member and stationary member with non-detergent SAE 30 weight oil just before installing rotor and shaft.

9. Coat rotor shaft with non-detergent SAE 30 weight oil. Start end of shaft in bracket bushing and turn from right to left, slowly pushing until ends of rotor teeth are just below face of casing.

Leave rotor in this position. Withdrawl of the rotor and shaft, may displace seal rotating face and result in damage to seal.

- Using a .010 to .015 inch head gasket, install head and idler assembly on pump. Pump head and casing were marked before disassembly to insure proper reassembly. If not, be sure idler pin, which is offset in pump head, is positioned toward and equal distance between port connections to allow for proper flow of liquid through pump.

Tighten head capscrews evenly.

Remove tapered installation sleeve from the shaft.

- If pump is equipped with jacketed head plate, install at this time along with new gasket.

If pump was equipped with a relief valve and was removed during disassembly, install on head with new gaskets. Relief valve adjusting screw cap must always point toward suction port. **Refer to Figures 1 & 2 on Page 1.** For relief valve repair or adjustments, **see Pressure Relief Valve Instructions, Page 9.**

- Slide inner spacer collar over shaft with recessed end facing rotor. H, HL, Q and M size bearing spacer collars are not recessed.

Place pair of half round rings on shaft and slide inner bearing spacer collar over half round rings to lock them in place. There is no pair of half round rings on H, HL, Q and M size pumps. **Refer to Figure 6, page 6.**

- Press lip seal, lip facing end of shaft, in inner end cap and insert end cap through shaft end of bracket. Turn end cap clockwise, looking at shaft end, until it engages threads. End cap spanner wrench holes must be facing rotor. Turn end cap with spanner wrench until it projects slightly from opening on side of bracket. End cap must not be turned so far that lip seal drops off end of spacer collar on shaft or end cap becomes disengaged from threads. **Refer to Figure 6, page 6.**

- Pack ball bearing with multi-purpose grease, NLGI #2. Place on shaft and push or gently drive in place in bracket.

- Press lip seal, lip facing end of shaft, in outer end cap and insert end cap in bracket. Turn end cap in bracket until it is tight against bearing. **Refer to Figure 6, page 6.**

- Put lockwasher and locknut on shaft. Insert length of hardwood or brass through port opening between rotor teeth to keep shaft from turning.

Tighten locknut to 50-70 ft.- lbs. Torque (H-HL) or 100-130 ft. – lbs. Torque (K-LL) or 170-190 ft. – lbs. Torque (Q-M). Bend one tang of lockwasher into slot of locknut. If tang does not line up with slot, tighten locknut until it does. Failure to tighten locknut or engage lockwasher tang could result in early bearing failure and cause damage to rest of pump.

Remove length of hardwood or brass from port opening.

Adjust pump end clearance. **Refer to Thrust Bearing Adjustment.**

Lubricate grease fitting over seal chamber with petroleum jelly, petrolatum (Vaseline) or other similar low melting point lubricant. Lubricate all other grease fittings with multi-purpose grease, NLGI #2.

DANGER !

Before starting pump, be sure all drive equipment guards are in place.

Failure to properly mount guards may result in serious injury or death.

THRUST BEARING ADJUSTMENT

- Loosen setscrews over outer and inner end caps. Two for H and HL size pumps, four for all other sizes.
- Turn inner end cap clockwise, viewed from shaft end, until it projects slightly from bracket exposing approximately three threads.
- Turn outer end cap clockwise until rotor is tight against head and rotor shaft cannot be turned.
- Make a reference mark on bracket end, opposite a notch on outer end cap. Back off outer end cap required number of notches. **Refer to Figure 11.**

- End clearances set per Step 4 are adequate for viscosities up to 750 SSU (SAE 20 lube oil at room temperature). Higher viscosity liquids require additional end clearances.

As a general guideline, for viscosities between 750 and 7500 SSU (heavier lube oils) double the amount of end clearance indicated in Step 4; for viscosities between 7500 and 75,000 SSU (e.g., resins) triple the amount.

For specific recommendations for end clearances for viscosity or for operating temperatures above 225°F, check with your Viking representative or consult the factory.

- Tighten inner end cap with a spanner wrench. Tap spanner wrench lightly but **DO NOT OVER TIGHTEN** as it will only damage the threads.
- Tighten all setscrews that hold inner and outer end caps to prevent their turning in bracket.
- Rotor and shaft should turn smoothly by hand one complete revolution. If rotor and shaft doesn't turn smoothly, go back and repeat Thrust Bearing Adjustment Steps 1 through 8.

Pump Size	TURN OUTER END CAP C.C.W.		
	No. of Notches	Length on O.D.	Total End Clearance
H - HL	3	0.50	.003
K - LL	5	2.313	.005
Q - M	5	2.25	.010

FIGURE 11

PRESSURE RELIEF VALVE INSTRUCTIONS

DISASSEMBLY

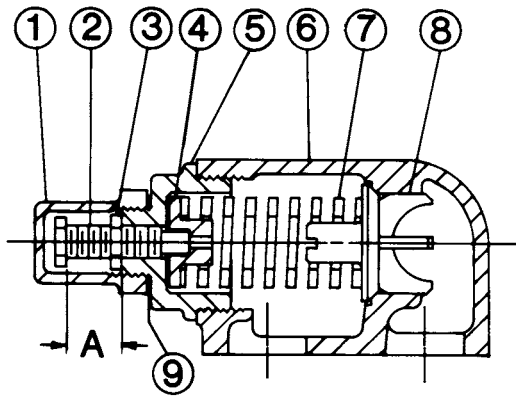

FIGURE 12
SIZE H AND HL

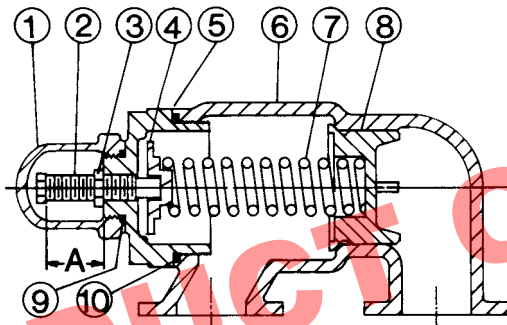

FIGURE 13
SIZE K, KK, L, LQ AND LL

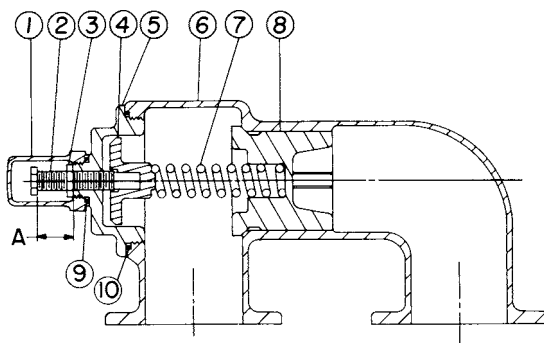

FIGURE 14
SIZE Q AND M

VALVE - LIST OF PARTS	
1. Valve Cap	6. Valve Body
2. Adjusting Screw	7. Valve Spring
3. Lock Nut	8. Poppet
4. Spring Guide	9. Cap Gasket
5. Bonnet	10. Bonnet Gasket

DANGER !

Before opening any Viking pump liquid chamber (pumping chamber, reservoir, relief valve adjusting cap fitting, etc.) Be sure:

1. That any pressure in the chamber has been completely vented through the suction or discharge lines or other appropriate openings or connections.
2. That the driving means (motor, turbine, engine, etc.) has been "locked out" or made non-operational so that it cannot be started while work is being done on pump.
3. That you know what liquid the pump has been handling and the precautions necessary to safely handle the liquid. Obtain a material safety data sheet (MSDS) for the liquid to be sure these precautions are understood.

Failure to follow above listed precautionary measures may result in serious injury or death.

Mark valve and head before disassembly to insure proper reassembly.

1. Remove valve cap.
2. Measure and record length of extension of adjusting screw. Refer to "A" on Figures 12, 13 and 14.
3. Loosen locknut and back out adjusting screw until spring pressure is released.
4. Remove bonnet, spring guide, spring and poppet from valve body. Clean and inspect all parts for wear or damage and replace as necessary.

ASSEMBLY

Reverse procedures outlined under Disassembly. If valve is removed for repairs, be sure to replace in same position. Relief valve adjusting screw cap must always point towards suction side of pump. If pump rotation is reversed, remove relief valve and turn end for end. Refer to Figures 1, 2, and 3, page 1.

DANGER !

Before starting pump, be sure all drive equipment guards are in place.

Failure to properly mount guards may result in serious injury or death.

PRESSURE ADJUSTMENT

If a new spring is installed or if pressure setting of pressure relief valve is to be changed from that which the factory has set, the following instructions must be carefully followed.

1. Carefully remove valve cap which covers adjusting screw.
Loosen locknut which locks adjusting screw so pressure setting will not change during operation of pump.
2. Install a pressure gauge in discharge line for actual adjustment operation.
3. Turn adjusting screw in to increase pressure and out to decrease pressure.
4. With discharge line closed at a point beyond pressure gauge, gauge will show maximum pressure valve will allow while pump is in operation.

IMPORTANT

In ordering parts for pressure relief valve, always give model number and serial number of pump as it appears on nameplate and name of part wanted. When ordering springs, be sure to give pressure setting desired.

**VIKING
PUMP****IDEX
CORPORATION**

WARRANTY

Viking warrants all products manufactured by it to be free from defects in workmanship or material for a period of one (1) year from date of startup, provided that in no event shall this warranty extend more than eighteen (18) months from the date of shipment from Viking. The warranty period for Universal Seal series pumps ONLY (Universal Seal models listed below) is three (3) years from date of startup, provided that in no event shall this warranty extend more than forty-two (42) months from the date of shipment from Viking.

UNDER NO CIRCUMSTANCES SHALL VIKING BE LIABLE UNDER THIS WARRANTY OR OTHERWISE FOR SPECIAL, INCIDENTAL, INDIRECT, CONSEQUENTIAL OR PUNITIVE DAMAGES OF ANY KIND, INCLUDING, BUT NOT LIMITED TO, LOSS OR UNREALIZED SALES, REVENUES, PROFITS, INCOME, COST SAVINGS OR BUSINESS, LOSS OR UNREALIZED CONTRACTS, LOSS OF GOODWILL, DAMAGE TO REPUTATION, LOSS OF PROPERTY, LOSS OF INFORMATION OR DATA, LOSS OF PRODUCTION, DOWNTIME, OR INCREASED COSTS, IN CONNECTION WITH ANY PRODUCT, EVEN IF VIKING HAS BEEN ADVISED OR PLACED ON NOTICE OF THE POSSIBILITY OF SUCH DAMAGES AND NOTWITHSTANDING THE FAILURE OF ANY ESSENTIAL PURPOSE OF ANY PRODUCT.

THIS WARRANTY IS AND SHALL BE VIKING'S SOLE AND EXCLUSIVE WARRANTY AND SHALL BE IN LIEU OF ALL OTHER WARRANTIES, EXPRESS OR IMPLIED, INCLUDING, BUT NOT LIMITED TO, ALL WARRANTIES OF MERCHANTABILITY, FITNESS FOR A PARTICULAR PURPOSE AND NON-INFRINGEMENT ALL OF WHICH OTHER WARRANTIES ARE EXPRESSLY EXCLUDED.

See complete warranty at www.vikingpump.com.