



# TECHNICAL SERVICE MANUAL

BEHIND THE ROTOR SEAL HEAVY DUTY PUMPS  
 SERIES 4124B AND 4224B CAST IRON  
 SIZES LS, Q, QS

SECTION	TSM 628.1
PAGE	1 OF 12
ISSUE	A

## CONTENTS

Safety Information & Instructions . . . . .	2
Special Information . . . . .	3
Maintenance . . . . .	3
Disassembly . . . . .	4
Assembly . . . . .	5
Seal Removal. . . . .	6
Thrust Bearing Adjustment . . . . .	6
Installation of Carbon Graphite Bushings . . . . .	6
Pressure Relief Valve Instructions . . . . .	7
Disassembly . . . . .	7
Assembly . . . . .	7
Pressure Adjustment . . . . .	7
Warranty . . . . .	8

UNMOUNTED PUMP		UNITS
Non-Jacketed	Jacketed	
LS4124B	LS4224B	Units are designated by the unmounted pump model numbers followed by a letter indicating drive style.  V = V-Belt D = Direct Connected R = Viking Speed Reducer P = Commercial Speed Reducer
Q4124B	Q4224B	
QS4124B	QS4224B	

**Note:** Series 4124B and 4224B pumps fitted with optional pinned-seat seals (the abrasive liquid seals used in 4624B Series pumps) should reference Technical Service Manual 410.5 for information on seal replacement.

## INTRODUCTION

The illustrations used in this manual are for identification purposes only and cannot be used for ordering parts. Obtain a parts list from a Viking representative. Always give a complete name of part, part number and material with the model number and serial number of pump when ordering repair parts. The unmounted pump or pump unit model number and serial number are on the nameplate.

In the Viking model number system, basic size letters are combined with series number (4124B, 4224B) indicating basic pump construction and material.

This manual deals only with Series 4124B and 4224B Heavy Duty Bracket Mounted Pumps. **Refer to Figures 1 through 11** for general configuration and nomenclature used in this manual. Pump specifications and recommendations are listed in Catalog Section 628, Viking Behind the Rotor Seal internal gear pumps.



FIGURE 2 - Q4224B



FIGURE 1 - LS4124B



FIGURE 3 - QS4124B

# SAFETY INFORMATION AND INSTRUCTIONS

IMPROPER INSTALLATION, OPERATION OR MAINTENANCE OF PUMP MAY CAUSE SERIOUS INJURY OR DEATH AND/OR RESULT IN DAMAGE TO PUMP AND/OR OTHER EQUIPMENT. VIKING'S WARRANTY DOES NOT COVER FAILURE DUE TO IMPROPER INSTALLATION, OPERATION OR MAINTENANCE.

THIS INFORMATION MUST BE FULLY READ BEFORE BEGINNING INSTALLATION, OPERATION OR MAINTENANCE OF PUMP AND MUST BE KEPT WITH PUMP. PUMP MUST BE INSTALLED, OPERATED AND MAINTAINED ONLY BY SUITABLY TRAINED AND QUALIFIED PERSONS.

THE FOLLOWING SAFETY INSTRUCTIONS MUST BE FOLLOWED AND ADHERED TO AT ALL TIMES.

Symbol Legend :



**Danger** - Failure to follow the indicated instruction may result in serious injury or death.

**WARNING**

**Warning** - In addition to possible serious injury or death, failure to follow the indicated instruction may cause damage to pump and/or other equipment.



**BEFORE** opening any liquid chamber (pumping chamber, reservoir, relief valve adjusting cap fitting, etc.) be sure that :

- Any pressure in the chamber has been completely vented through the suction or discharge lines or other appropriate openings or connections.
- The pump drive system means (motor, turbine, engine, etc.) has been "locked out" or otherwise been made non-operational so that it cannot be started while work is being done on the pump.
- You know what material the pump has been handling, have obtained a material safety data sheet (MSDS) for the material, and understand and follow all precautions appropriate for the safe handling of the material.

**WARNING**

**INSTALL** pressure gauges/sensors next to the pump suction and discharge connections to monitor pressures.



**WARNING**

**USE** extreme caution when lifting the pump. Suitable lifting devices should be used when appropriate. Lifting eyes installed on the pump must be used **only** to lift the pump, **not** the pump with drive and/or base plate. If the pump is mounted on a base plate, the base plate must be used for all lifting purposes. If slings are used for lifting, they must be safely and securely attached. For weight of the pump alone (which does not include the drive and/or base plate) refer to the Viking Pump product catalog.



**BEFORE** operating the pump, be sure all drive guards are in place.



**DO NOT** attempt to dismantle a pressure relief valve that has not had the spring pressure relieved or is mounted on a pump that is operating.



**DO NOT** operate pump if the suction or discharge piping is not connected.



**AVOID** contact with hot areas of the pump and/or drive. Certain operating conditions, temperature control devices (jackets, heat-tracing, etc.), improper installation, improper operation, and improper maintenance can all cause high temperatures on the pump and/or drive.



**DO NOT** place fingers into the pumping chamber or its connection ports or into any part of the drive train if there is **any possibility** of the pump shafts being rotated.



**WARNING**

**THE PUMP** must be provided with pressure protection. This may be provided through a relief valve mounted directly on the pump, an in-line pressure relief valve, a torque limiting device, or a rupture disk. If pump rotation may be reversed during operation, pressure protection must be provided on **both** sides of pump. Relief valve adjusting screw caps must always point towards suction side of the pump. If pump rotation is reversed, position of the relief valve must be changed. Pressure relief valves cannot be used to control pump flow or regulate discharge pressure. For additional information, refer to Viking Pump's Technical Service Manual TSM 000 and Engineering Service Bulletin ESB-31.

**WARNING**

**DO NOT** exceed the pumps rated pressure, speed, and temperature, or change the system/duty parameters from those the pump was originally supplied, without confirming its suitability for the new service.



**WARNING**

**BEFORE** operating the pump, be sure that:

- It is clean and free from debris
- all valves in the suction and discharge pipelines are fully opened.
- All piping connected to the pump is fully supported and correctly aligned with the pump.
- Pump rotation is correct for the desired direction of flow.



**WARNING**

**THE PUMP** must be installed in a matter that allows safe access for routine maintenance and for inspection during operation to check for leakage and monitor pump operation.

## SPECIAL INFORMATION

### DANGER !

Before opening any Viking pump liquid chamber (pumping chamber, reservoir, relief valve adjusting cap fitting, etc.) Be sure:

1. That any pressure in the chamber has been completely vented through the suction or discharge lines or other appropriate openings or connections.
2. That the driving means (motor, turbine, engine, etc.) has been "locked out" or made non-operational so that it cannot be started while work is being done on pump.
3. That you know what liquid the pump has been handling and the precautions necessary to safely handle the liquid. Obtain a material safety data sheet (MSDS) for the liquid to be sure these precautions are understood.

Failure to follow above listed precautionary measures may result in serious injury or death.

**ROTATION:** Viking pumps operate equally well in a clockwise or counterclockwise rotation. Shaft rotation determines which port is suction and which is discharge. Port in area where pumping elements (gear teeth) come out of mesh is suction port.

#### **PRESSURE RELIEF VALVES:**

1. Viking pumps are positive displacement pumps and must be provided with some sort of pressure protection. This may be a relief valve mounted directly on the pump, an inline pressure relief valve, a torque limiting device or a rupture disk.
2. There are relief valve options available on those pump models designed to accept a relief valve. Options may include a return to tank relief valve and a jacketed relief valve. Pumps equipped with a jacketed head plate are generally not available with a relief valve.
3. If pump rotation is reversed during operation, pressure protection must be provided on **both** sides of pump.
4. Relief valve adjusting screw cap must **always** point towards suction side of pump. If pump rotation is reversed, remove pressure relief valve and turn end for end.
5. Pressure relief valves cannot be used to control pump flow or regulate discharge pressure.

For additional information on pressure relief valves, **Refer** to Technical Service Manual TSM000 and Engineering Service Bulletin ESB-31.

#### **SPECIAL MECHANICAL SEALS:**

Extra care should be taken in repair of these pumps. Be sure to read and follow all special instructions supplied with your pump.

## MAINTENANCE

Viking pumps are designed for long, trouble-free service life under a wide variety of application conditions with a minimum of maintenance. The points listed below will help provide long service life.

**LUBRICATION:** External lubrication must be applied slowly with a hand gun to all lubrication fittings every 500 hours of operation with multi-purpose grease, NLGI # 2. **Refer to Engineering Service Bulletin ESB-515.** Consult factory with specific lubrication questions. Applications involving very high or low temperatures will require other types of lubrication.

**CLEANING PUMP:** Keep pump as clean as possible. This will facilitate inspection, adjustment and repair work and help prevent overlooking a dirt covered grease fitting.

**STORAGE:** If pump is to be stored, or not used for six months or more, pump must be drained and a light coat of light oil must be applied to all internal pump parts.

Lubricate fittings and apply grease to pump shaft extension. Viking suggests rotating pump shaft by hand one complete revolution every 30 days to circulate the oil.

**SUGGESTED REPAIR TOOLS:** The following tools must be available to properly repair Universal Seal Bracket Pumps. These tools are in addition to standard mechanics' tools such as open-end wrenches, pliers, screwdrivers, etc. Most of the items can be obtained from an industrial supply house.

1. Soft Headed hammer
2. Allen wrenches (some mechanical seals and set collars)
3. Mechanical seal installation sleeve  
2-751-005-630 for 2.4375 inch seal; Q-QS pumps.
4. Bearing locknut spanner wrench  
(Source: #472 J. H. Williams & Co. or equal);  
LS-QS pumps.
5. Spanner wrench, adjustable pin type for use on bearing housing (Source: #482 J. H. Williams & Co. or equal)
6. Brass bar
7. Arbor press

# DISASSEMBLY

## DANGER !

Before opening any Viking pump liquid chamber (pumping chamber, reservoir, relief valve adjusting cap fitting, etc.) Be sure:

1. That any pressure in the chamber has been completely vented through the suction or discharge lines or other appropriate openings or connections.
2. That the driving means (motor, turbine, engine, etc.) has been "locked out" or made non-operational so that it cannot be started while work is being done on pump.
3. That you know what liquid the pump has been handling and the precautions necessary to safely handle the liquid. Obtain a material safety data sheet (MSDS) for the liquid to be sure these precautions are understood.

Failure to follow above listed precautionary measures may result in serious injury or death.

1. Mark head and casing before disassembly to insure proper reassembly. The idler pin, which is offset in pump head, must be positioned toward and equal distance between port connections to allow for proper flow of liquid through the pump.

Remove head from pump. Do not allow idler to fall from idler pin. Tilt top of head back when removing to prevent this. Avoid damaging head gasket. If pump is furnished with pressure relief valve, it need not be removed from head or disassembled at this point. **Refer to Pressure Relief Valve Instructions, page 8.**

If pump has jacketed head plate, it will separate from head when it is removed. Reinstall the O-Ring when assembling pump.

2. Remove idler and bushing assembly.
3. Insert length of hardwood or brass through port opening between rotor teeth or lock coupling end of shaft to keep shaft from turning. Bend up tang of lockwasher, and with a spanner wrench, remove locknut and lockwasher from shaft.
4. Loosen two setscrews in the face of the bearing housing and remove the bearing housing assembly from the bracket. **Refer to Figure 5 or 6, page 5.**
5. Remove pair of half round rings under the inner spacer collar from the shaft. **NOTE:** There are no half round rings on Q and QS size pumps.
6. Carefully remove rotor and shaft to avoid damaging bracket bushing. If damaged or worn, remove bushing.
7. Remove bracket lip seal (Item 18).
8. Loosen two radial setscrews in flange of bearing housing and with a spanner wrench remove the outer end cap with closure and outer bearing spacer collar.

## REPAIR: MODELS LS, Q AND QS BEHIND THE ROTOR COMPONENT MECHANICAL SEAL PUMPS

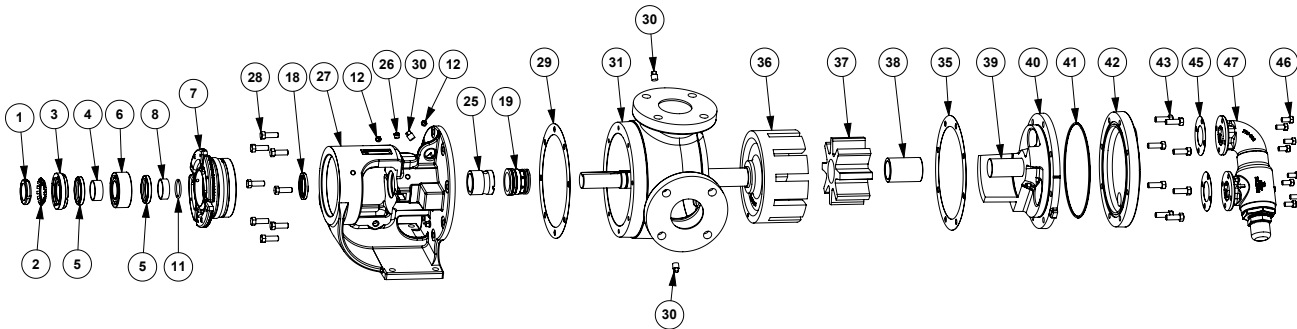

ITEM	NAME OF PART	ITEM	NAME OF PART	ITEM	NAME OF PART
1	Locknut	19	Mechanical Seal	38	Idler Bushing
2	Lockwasher	25	Bracket Bushing	39	Idler Pin
3	End Cap	26	Pressure Relief Fitting for Bracket	40	Head and Idler Pin Assembly
4	Bearing Spacer Collar (Outer)	27	Bracket	41	O-Ring for Jacket Head Plate (4224B)
5	Lip Seal	28	Capscrew for Bracket	42	Jacket Head Plate (4224B)
6	Bearing (Ball or Tapered Roller)	29	Bracket Gasket	43	Capscrew for Head
7	Bearing Housing	30	Pipe Plug	45	Relief Valve Gasket
8	Bearing Spacer Collar (Inner)	31	Casing (Tapped or Flanged)	46	Capscrew for Relief Valve
11	Ring, Half Round (Not Q, QS)	35	Head Gasket	47	Internal Relief Valve
12	Grease Fitting	36	Rotor and Shaft		
18	Lip Seal	37	Idler		

FIGURE 4 – EXPLODED VIEW SERIES 4124B MODELS

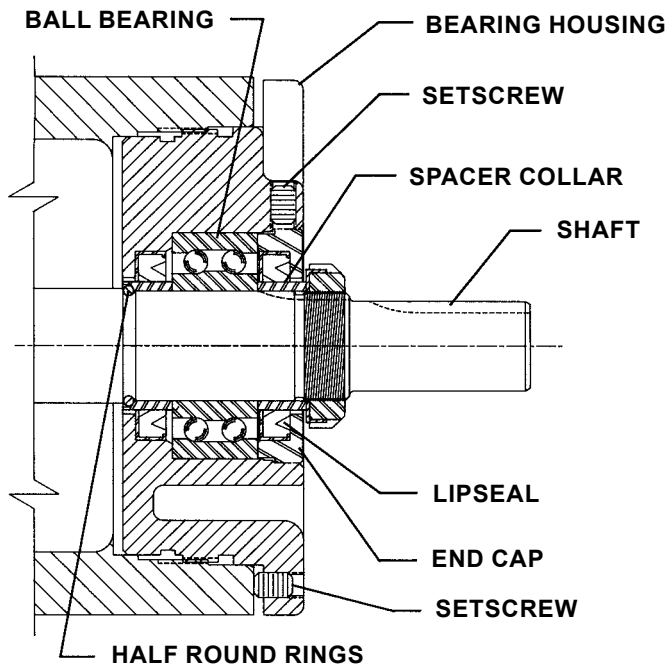

**FIGURE 5**  
**LS BEARING HOUSING ASSEMBLY**

9. Remove the double row ball bearing, (2 tapered roller bearings on Q and QS sizes), closure and inner bearing spacer collar from the bearing housing.
10. Remove the rotary member of the mechanical seal from the rotor shaft. Remove the seal seat from the bracket.
11. Clean all parts thoroughly and examine for wear and damage. Check lip seals, bearings, bushings, and idler pin and replace if necessary. Check all other parts for nicks, burrs, excessive wear and replace if necessary. Wash bearings in clean solvent. Blow out bearings with compressed air. Do not allow bearings to spin; turn them slowly by hand. Spinning bearings will damage bearing components. Make sure bearings are clean, then lubricate with light oil and check for roughness. Roughness can be determined by turning outer race by hand.

**CAUTION:** Do not intermix inner and outer races of tapered roller bearing (Q and QS sizes).

12. Casing can be checked for wear or damage while mounted on bracket.

## ASSEMBLY

1. Install new bracket bushing, if replacement is needed. If bracket bushing has an inner lubrication groove, install bushing with groove at six o'clock position in bracket. If carbon graphite, **Refer to Installation of Carbon Graphite Bushings, page 7.**
2. Clean rotor shaft and seal housing bore. Make sure they are free of dirt, grit, and scratches. Gently clean the radius leading edge of shaft diameter over which seal is to be placed. Never touch mechanical seal faces with anything except clean hands or clean cloth. Minute particles can scratch the seal faces and cause leakage.

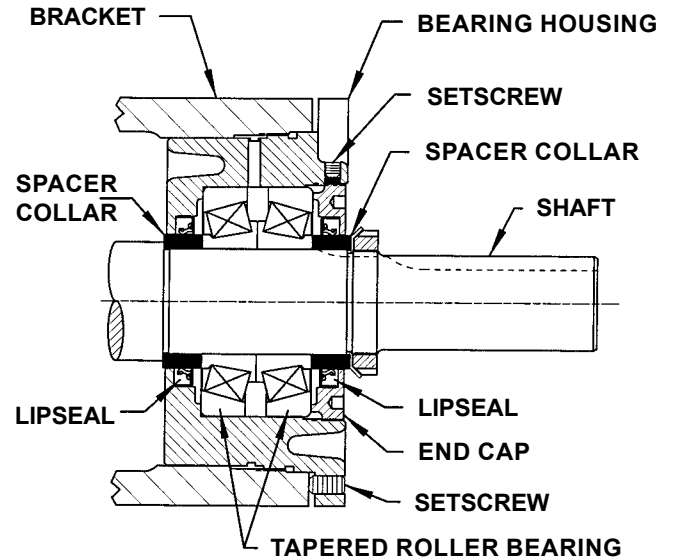

**FIGURE 6**  
**Q-QS BEARING HOUSING ASSEMBLY**

3. Place tapered installation sleeve on the shaft. Coat the tapered sleeve and inside of the rotary member with a generous quantity of light oil. Grease is not recommended. Start rotary member on shaft and over tapered sleeve. **Refer to Figure 7.**
4. Move rotary member all the way on the rotor shaft until it is against the rotor hub. If the seal uses setscrews to secure the seal to the shaft, tighten the setscrews once the seal is in place. Some PTFE seals are equipped with holding clips which compress the seal springs. Remove the holding clips to release springs after seal is installed on shaft.
5. Lubricate outer diameter of seal seat gasket with oil. Press seal seat into bracket bore until back, unlapped face bottoms in bore. Make sure the seat anti-rotation pins are aligned with slots in the bracket bushing.
6. Coat shaft of rotor shaft assembly with light oil. Start end of shaft in bracket bushing turning from right to left, slowly pushing rotor in casing.
7. Coat idler pin with light oil and place idler and bushing on idler pin in head. If replacing with carbon graphite bushing, **Refer to Installation of Carbon Graphite Bushings, page 7.**

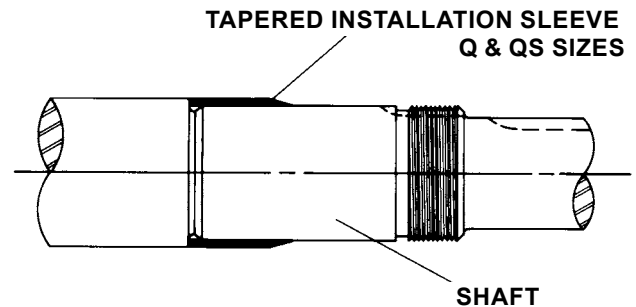

**COAT ROTOR SHAFT, TAPERED INSTALLATION SLEEVE AND INNER DIAMETER OF MECHANICAL SEAL WITH LIGHT OIL BEFORE ASSEMBLY.**

**FIGURE 7**



- Using a .010 to .015 inch thick head gasket, install head and idler assembly on pump. Pump head and casing should have been marked before disassembly to ensure proper reassembly. If not, be sure idler pin, which is offset in pump head, is positioned toward the equal distance between port connections to allow for proper flow of liquid through pump. If pump is equipped with jacketed headplate, install at this time along with new gasket.

Refer to **Figure 5 & 6, page 5** for bearing housing assembly.

- Install bracket lip seal (Item 18).
- Install lip seal (lip toward end of shaft) in bearing housing.
- “LS” Pumps:** Pack the ball bearing with grease and push or press the bearing into the bearing housing. Refer to **Figure 5, page 5**.

**Q and QS Size Pumps:** Pack tapered roller bearings with grease and press or push bearings into housing with large end of inner races together. It is possible to install bearings incorrectly. For proper assembly see Figure 6.

- Install the lip seal in the end cap (with lip toward end of shaft). Thread the end cap into the bearing housing along with outer bearing spacer collar and tighten against the bearing.

**Q and QS SIZE PUMPS ONLY:** Tapered roller bearings require preload to operate properly. To set preload tighten end cap so that inner races of bearings cannot be rotated by hand. Back the end cap off to allow inner races to rotate with slight resistance.

Lock end cap in place with two setscrews in the flange of the bearing housing.

- Slide inner spacer collar over shaft with recessed end facing rotor. Q and QS bearing spacer collars are not recessed.

Place pair of half round rings on shaft and slide inner bearing spacer collar over half round rings to lock them in place. There is no pair of half round rings on Q and QS size pumps.

- Thread the bearing housing with lip seals; end cap, outer bearing spacer collar and bearings installed into bracket.
- Put lockwasher and locknut on shaft. Insert length of hardwood or brass through port opening between rotor teeth to keep shaft from turning. Tighten locknut to 120-150 - ft.lbs. torque (LS) or 170-190 - ft.lbs. torque (Q and QS) . If tang does not line up with slot, tighten locknut until it does. Failure to tighten locknut or engage lockwasher tang could result in early bearing failure and cause damage to rest of pump. Remove length of hardwood or brass from port opening.
- Adjust pump end clearance as in **Thrust Bearing Adjustment, page 7**.

## RELUBRICATION

Before putting pump back into service, add grease to the bracket grease fitting until it comes out of the relief fitting on the opposite side of the bracket (use petroleum jelly, petrolatum or other similar low melting point lubricant). Regrease the bearing housing until grease comes out of the shaft end lip seal (use multi-purpose grease NLGI #2).

## DANGER !

**Before starting pump, be sure all drive equipment guards are in place.**

**Failure to properly mount guards may result in serious injury or death.**

## THRUST BEARING ADJUSTMENT

- Loosen the two set screws in the outer face of the bearing housing and turn this thrust bearing assembly clockwise until it can no longer be turned by hand. Back off counter-clockwise until the rotor shaft can be turned by hand with a slight noticeable drag.
- For standard end clearance, back off the thrust bearing assembly the required length measured on the outside diameter of the bearing housing. See **Table 1**.
- Tighten the two self-locking type “Allen” set screws, in the outboard face of the bearing housing, with equal force against the bracket. Your pump is now set with standard end clearances and locked.

**NOTE:** Be sure the shaft can rotate freely. If not, back off additional length on outside diameter and check again.

- High viscosity liquids required additional end clearances. The amount of extra end clearance depends on the viscosity of the liquid pumped. For specific recommendations, consult the factory. Table 1 shows the additional bearing housing adjustment required for .001” increase in end clearance.

PUMP SIZE & MODEL	STANDARD END CLEARANCE (Inch)	TURN BRG. HOUSING C.C.W. LENGTH ON O.D. (Inch)	ADDITIONAL LENGTH ON O.D. BRG. HOUSING FOR .001” END CL. (Inch)
LS 4124B	0.005	1.25	0.25
LS 4224B	0.01	2.50	0.25
Q & QS 4124B	0.01	3.10	0.31
Q & QS 4224B	0.015	4.65	0.31

TABLE 1

## INSTALLATION OF CARBON GRAPHITE BUSHINGS

When installing carbon graphite bushings, extreme care must be taken to prevent breaking. Carbon graphite is a brittle material and easily cracked. If cracked, the bushing will quickly disintegrate. Using a lubricant and adding a chamfer on the bushing and the mating part will help in installation. The additional precautions listed below must be followed for proper installation.

- A press must be used for installation.
- Be certain bushing is started straight.
- Do not stop pressing operation until bushing is in proper position. Starting and stopping will result in a cracked bushing.
- Check bushing for cracks after installation.

Carbon graphite bushings with extra interference fits are frequently furnished for high temperature operation. These bushings must be installed by a shrink fit.

1. Heat bracket for idler to 750°F.
2. Install cool bushing with a press.
3. If facilities are not available to reach 750°F temperature, it is possible to install with 450°F temperature; however the lower the temperature the greater the possibility of cracking the bushing.
4. Consult factory with specific questions on high temperature applications. Refer to Engineering Service Bulletin ESB-3.

## PRESSURE RELIEF VALVE INSTRUCTIONS

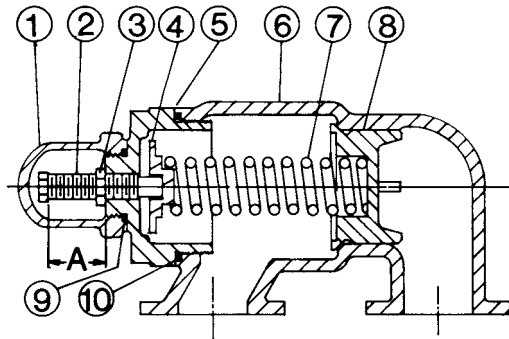

VALVE - LIST OF PARTS	
1. Valve Cap	6. Valve Body
2. Adjusting Screw	7. Valve Spring
3. Lock Nut	8. Poppet
4. Spring Guide	9. Cap Gasket
5. Bonnet	10. Bonnet Gasket

**FIGURE 10**  
SIZE LS

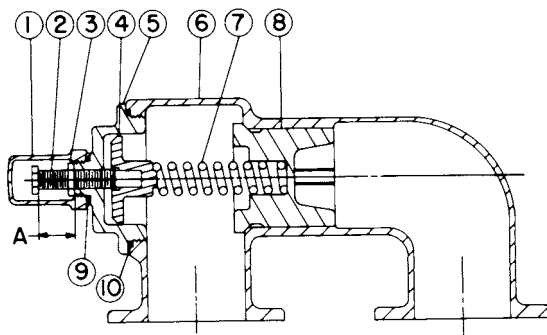

VALVE - LIST OF PARTS	
1. Valve Cap	6. Valve Body
2. Adjusting Screw	7. Valve Spring
3. Lock Nut	8. Poppet
4. Spring Guide	9. Cap Gasket
5. Bonnet	10. Bonnet Gasket

**FIGURE 11**  
SIZES Q AND QS

## DISASSEMBLY

Mark valve and head before disassembly to insure proper reassembly.

1. Remove valve cap.
2. Measure and record length of extension of adjusting screw. Refer to "A" on Figure 10 and Figure 11, page 9.
3. Loosen locknut and back out adjusting screw until spring pressure is released.
4. Remove bonnet, spring guide, spring and poppet from valve body. Clean and inspect all parts for wear or damage and replace if necessary.

## ASSEMBLY

Reverse procedures outlined under Disassembly. If valve is removed for repairs be sure to replace in same position. Relief valve adjusting screw cap must always point towards suction side of pump. If pump rotation is reversed, remove relief valve and turn end for end.

## PRESSURE ADJUSTMENT

If a new spring is installed or if pressure setting of pressure relief valve is to be changed from that which the factory has set, the following instructions must be carefully followed.

1. Carefully remove valve cap, which covers adjusting screw.
2. Loosen locknut (which locks adjusting screw so pressure setting will not change during operation of pump).
3. Install a pressure gauge in discharge line for actual adjusting operation.
4. Turn adjusting screw in to increase pressure and out to decrease pressure.
5. With discharge line closed at point beyond pressure gauge and pump running, gauge will show maximum pressure that the valve will allow (full bypass).

## IMPORTANT

In ordering parts for pressure relief valve, always give model number and serial number of pump as it appears on nameplate and name of part wanted. When ordering springs, be sure to give pressure setting desired.



# TECHNICAL SERVICE MANUAL

BEHIND THE ROTOR SEAL HEAVY DUTY PUMPS  
SERIES 4124B AND 4224B CAST IRON  
SIZES LS, Q, QS

SECTION	TSM 628.1
PAGE	8 OF 8
ISSUE	A

## VIKING PUMP

### WARRANTY

Viking pumps, strainers and reducers are warranted to be free of defects in material and workmanship under normal conditions of use and service. The warranty period varies by type of product. A Viking product that fails during its warranty period under normal conditions of use and service due to a defect in material or workmanship will be repaired or replaced by Viking. At Viking's sole option, Viking may refund (in cash or by credit) the purchase price paid to it for a Viking product (less a reasonable allowance for the period of use) in lieu of repair or replacement of such Viking product. Viking's warranty is subject to certain restrictions, limitations, exclusions and exceptions. A complete copy of Viking's warranty, including warranty periods and applicable restrictions, limitations, exclusions and exceptions, is posted on Viking's website ([www.vikingpump.com/warranty/warranty-info](http://www.vikingpump.com/warranty/warranty-info)). A complete copy of the warranty may also be obtained by contacting Viking through regular mail at Viking Pump, Inc., 406 State Street, Cedar Falls, Iowa 50613, USA.

THIS WARRANTY IS AND SHALL BE VIKING'S SOLE AND EXCLUSIVE WARRANTY AND IS IN LIEU OF ALL OTHER WARRANTIES, EXPRESS OR IMPLIED, INCLUDING, BUT NOT LIMITED TO, ALL WARRANTIES OF MERCHANTABILITY, FITNESS FOR A PARTICULAR PURPOSE AND NON-INFRINGEMENT, ALL OF WHICH OTHER WARRANTIES ARE EXPRESSLY EXCLUDED.

THE RIGHTS AND REMEDIES UNDER THIS WARRANTY ARE AND SHALL BE THE SOLE AND EXCLUSIVE RIGHTS AND REMEDIES AGAINST VIKING. EXCEPT FOR THE SPECIFIC LIABILITIES AND OBLIGATIONS PROVIDED UNDER THIS WARRANTY, VIKING SHALL HAVE NO LIABILITY OR OBLIGATION WITH RESPECT TO ANY PRODUCT CLAIMED TO BE DEFECTIVE IN ANY MANNER.

UNDER NO CIRCUMSTANCES SHALL VIKING BE LIABLE UNDER THIS WARRANTY OR OTHERWISE FOR SPECIAL, INCIDENTAL, INDIRECT, CONSEQUENTIAL OR PUNITIVE DAMAGES OF ANY KIND, INCLUDING, BUT NOT LIMITED TO, LOST OR UNREALIZED SALES, REVENUES, PROFITS, INCOME, COST SAVINGS OR BUSINESS, LOST OR UNREALIZED CONTRACTS, LOSS OF GOODWILL, DAMAGE TO REPUTATION, LOSS OF PROPERTY, LOSS OF INFORMATION OR DATA, LOSS OF PRODUCTION, DOWNTIME, OR INCREASED COSTS, IN CONNECTION WITH ANY PRODUCT, EVEN IF VIKING HAS BEEN ADVISED OR PLACED ON NOTICE OF THE POSSIBILITY OF SUCH DAMAGES AND NOTWITHSTANDING THE FAILURE OF ANY ESSENTIAL PURPOSE OF ANY PRODUCT.