



TECHNICAL SERVICE MANUAL

LID-EASE[®] SIMPLEX IN-LINE BASKET-TYPE STRAINERS

SECTION	TSM 640
PAGE	1
ISSUE	G

CONTENTS

Introduction.....	1
Contents.....	1
Special Information.....	1
Installation.....	2
Disassembly.....	2
Assembly.....	2
Assembly (Cont.).....	3
O-ring Information.....	3
Warranty.....	4

INTRODUCTION

This bulletin deals exclusively with Viking Lid-Ease[®] Basket-Type Strainers. When ordering parts be sure to give complete part name, serial number and model number (cast on body below serialized nameplate). The basket mesh size is stamped on the basket handle and the o-ring construction can be identified with a Viking color code (listed under O-Ring Information).

Use of basket strainers can avoid costly failures and increase the life of the equipment. Proper use of strainer can minimize down time. A definition for strainers is "a coarse filter". Strainers are typically intended to trap larger foreign objects

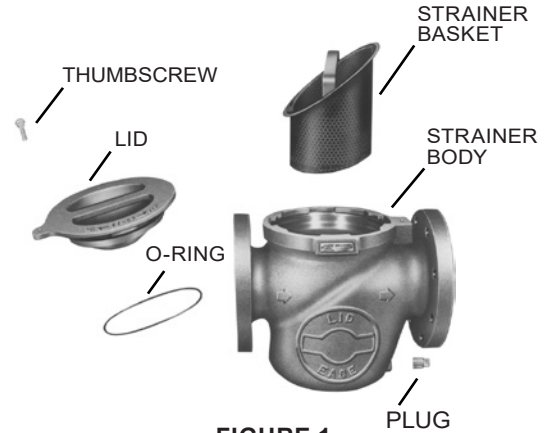

FIGURE 1

such as rags, weld beads or bolts. Filters are intended to capture very small particles.

Lid sealing is accomplished with one o-ring, therefore proper application of o-ring is essential. The o-ring must be acceptable for the temperature limits of the system as well as compatible with the fluid being strained. Misapplication may result in o-ring swell, (making lid removal difficult) or premature o-ring failure, causing strainer leakage.

SPECIAL INFORMATION

DANGER !

Before opening any Viking product (Strainer, pumping chamber, reservoir, relief valve adjusting screw cap etc.) be sure:

1. That any pressure in the strainer or pumping chamber has been completely vented through suction or discharge lines or other appropriate openings or connections.
2. That the driving means (motor, turbine, engine, etc.) has been "Locked Out" or made non-operational so that it cannot be started while maintenance is being preformed.
3. That you know what liquid the strainer has been handling and the necessary precautions to safely handle the liquid. Obtain a Material Safety Data Sheet (MSDS) for the liquid to be sure these precautions are understood.

Failure to follow above listed precautionary measures may result in serious injury or death.

Viking does not recommend using Lid-Ease Strainers for the following applications:

1. Fluids having vapor pressure higher than one atmosphere, either at room temperature or operating temperature.
2. Straining of particles finer than 70 microns (50X250 Mesh available through 4").
3. Temperatures below -40 °F or above +400 °F.
4. High system pressure applications (See Table A, Page 2).
5. High basket differential pressure (See Table A).

Determine and exercise necessary precautions before removing the lid, involving fluids which are:

- **POISONOUS OR TOXIC**
- **FLAMMABLE**
- **HARMFUL TO FACE OR HANDS**
- **HOT** (Liquids containing boiling water (+212° F at sea level) can produce steam; extra care to properly vent strainer must be exercised).
- **ENTRAINED WITH AIR** (Trapped, pressurized air under lid can lift the lid suddenly and violently if the lid is rotated. Be the sure system is completely vented)

DO NOT ATTEMPT TO VENT THE SYSTEM BY TURNING THE LID.

Strainer Size	1"	1 1/2"	2"	3"	4"	6"	8"
Basket Clearance (Required from port centerline)	6.0	6.5	7.5	9.5	11.75	16.5	24.5
Maximum Basket Differential Pressure (PSID)	150	150	150	125	125	75	50
Maximum System Pressure (PSIG)	200	200	200	① 125	① 125	① 125	① 125

① 175 PSI on liquid temperature below 150 °F

TABLE A

INSTALLATION

Strainers should be placed ahead of any equipment needing protection. The mesh size used in the strainer body should be only as small as required to protect the equipment. This will minimize the pressure drop through the strainer. For pump protection locate the strainer on suction side of the pump. Proper sizing of the strainer and basket mesh can prevent the pump from cavitating due to excessive pressure drop across the strainer. There are several factors which influence pressure drop such as viscosity of fluid, percentage and size of particles or contaminants, and frequency of cleaning.

If the liquid contains undesirable ferrous particles, magnetic inserts can be added to the baskets to help remove these particles.

A second strainer (or filter) located on discharge side of pump may be desirable to protect other equipment in the system which requires a smaller mesh basket for finer straining of the liquid. A basket with a smaller mesh opening (the higher the mesh number, the smaller the opening in the mesh) can be permitted on the discharge side because pressure drop is less critical. Maximum differential pressures allowable across strainers are listed in **Table A**.

Locate the strainer in a position where the drain plug can be easily removed (Replace the plug with a drain valve for frequent maintenance). Provide adequate space above the strainer for basket removal as listed in table A. The Lid-Ease strainer has cast arrows on the body to indicate the direction fluid must flow. These strainers are not designed for any type of backwash operation.

NOTE: Mounting the strainer with ports in a vertical position is **NOT** recommended because of increased difficulty during servicing.

For the larger strainers, additional external support of the strainer may be required to reduce pipe strain in the system. This can be accomplished either by supporting the flanges or providing a base for the bottom of the strainer. Lid removal for maintenance will be much easier if the top of the strainer is not over 3 feet off the ground. In the event that the strainer is not at highest point in the system, valves are recommended on both sides of strainer to prevent the strainer from filling up while cleaning the basket.

As the basket becomes clogged with foreign matter, differential pressure will rise. **Table A** shows maximum pressure differential allowable across the basket. If this pressure is exceeded, damage to the basket may occur. A good way to indicate when basket must be cleaned is to: 1)

Install a pressure differential gauge or 2) install a pressure gauge on each side of the strainer.

NOTE: Strainers located on the discharge side of the pump must have a safety relief valve between the pump and the strainer set no higher than the strainer's maximum system pressure (see Table A).

DISASSEMBLY

NOTE: Before removing the lid to clean the basket make sure that you have a spare o-ring in the event that the fluid being strained has caused the o-ring to swell.

DANGER !

Before opening any Viking product (Strainer, pumping chamber, reservoir, relief valve adjusting screw cap etc.) be sure:

1. That any pressure in the strainer or pumping chamber has been completely vented through suction or discharge lines or other appropriate openings or connections.
2. That the driving means (motor, turbine, engine, etc.) has been "Locked Out" or made non-operational so that it cannot be started while maintenance is being performed.
3. That you know what liquid the strainer has been handling and the necessary precautions to safely handle the liquid. Obtain a Material Safety Data Sheet (MSDS) for the liquid to be sure these precautions are understood.

Failure to follow above listed precautionary measures may result in serious injury or death.

1. Remove the thumbscrew from top of lid.
2. Rotate the weatherseal lid counter clockwise until the pin hits and stops. (The lid features an internal pin, which locates the on and off positions.)
3. Raise up the lid.
4. Remove the basket and clean. Do not strike the basket to clean it out; this could deform the basket side or lip and decrease the strainers effectiveness. Avoid using a sharp object such as a screwdriver, which could puncture the mesh. To clean the basket, use a small brush or compressed air.

ASSEMBLY

1. Place basket into strainer body.
2. Reinstall the lid with the tab of the lid just to the left of the boss with the threaded hole on the body (See fig. 2).

NOTE: Do not attempt to install the lid if the strainer has filled up; drain before installing the lid. Press down on the lid firmly and evenly until it pops into place.

ASSEMBLY (Cont.)

3. Rotate the lid clockwise until the two holes line up.
4. Reinsert the thumbscrew.
5. Reinstall the drain plug (if removed) or close the drain valve (if installed).
6. Before starting up the system, make sure to open all valves that were closed for servicing. After starting up the system, check for any possible leaks. If there is any leakage around the lid, return to Disassembly. Remove the lid and refer to Trouble-Shooting, page 4, for possible causes of leakage.

NOTE: When installing a new o-ring, it is recommended that the o-ring be lubricated with grease before installing onto the lid.

DANGER !

Before starting the system, be sure the lid is turned to the proper position and the thumbscrew is installed to prevent the lid from turning

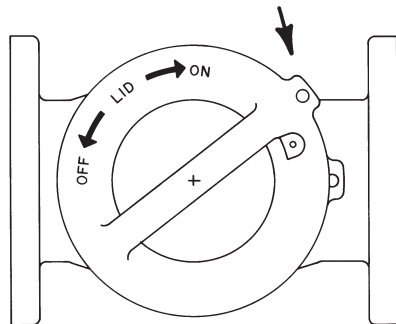

FIGURE 2

O-RING INFORMATION

Proper application and use of the o-ring elastomer will affect the ease of lid removal and the life of the o-ring. Compatibility of the elastomer with the fluid(s) at operating temperature extremes, is essential and **Table B** lists suitability for several o-ring elastomers, along with Viking's means of identification. If an o-ring is incompatible with a fluid, excessive o-ring swell or contraction might result and/or properties of the elastomer may change, reducing the satisfactory performance life of the o-ring. Included in Table B is a general list of fluids that Parker's O-Ring Manual does and does not recommend for specific elastomers. Obviously if an o-ring should swell, sealing will be enhanced between lid and body, but would make the lid difficult to remove. Conversely, o-ring shrinkage will reduce sealing and possibly cause a leak. Several good sources are available covering o-ring compatibility. These include o-ring manufacturers literature, Viking Pump's Liquid List, Viking's Application Department, manufacturers of other components in the system and previous experience.

Generally it is best to have an extra o-ring on hand when removing the lid. Once the lid has been removed, if any swelling has occurred, reinstalling the lid with the existing o-ring will be difficult (if not impossible) and may require another o-ring. Once o-ring dries out, it can sometimes be used again.

PTFE (Derivative) Encapsulated o-rings generally do not swell. Do not attempt to reuse this type of o-ring if it has been removed. Immerse a new o-ring in boiling water for a few minutes. Remove from the water and stretch out the o-ring so it will fit onto the casing hub of the lid without forcing it over a sharp edge. Run hot water over the o-ring until it shrinks down tight into the groove of lid.

**TABLE B
O-RING SELECTION**

TYPE OF ELASTOMER	VIKING IDENTIFICATION	TEMPERATURE LIMIT ① LIMIT °F	LIQUIDS ②	
			RECOMMENDED	NOT RECOMMENDED
BUNA	NO DOT	-20 TO +225	Petroleum, oils and fluids Silicone greases & oils Ethylene glycol base General purpose sealing	Halogenated hydrocarbon Nitro hydrocarbon Phosphate ester Ketones Ozone Automotive break fluid
FKM	GREEN DOT	-15 TO +400	Petroleum oils Di-Ester base lubricant Silicone fluids & grease Halogenated hydrocarbon Selected phosphate ester acids	Ketones Skydrol Amines Low molecular weight esters & ethers Hot hydrofluoric or chlorosulfonic acids
ETHYLENEPROPYLENE RUBBER	ORANGE DOT	-65 TO +300	Water Dilute Acids Dilute alkalies Ketones Alcohol	Petroleum Oil Di-Ester base lubricant
SANITARY	YELLOW DOT	-20 TO +225	Same as Buna-N	
PTFE (DERIVATIVE) ENCAPSULATED	NO DOT ORANGE CORE	(STANDARD) -40 TO +300	Most solvents & chemicals	Molten alkali metals
	NO DOT PURPLE CORE	(HIGH TEMP) -40 TO +400	Consult factory if unsure about compatibility	Fluorine and strong fluorinating agents

① Temperatures listed are for static seal applications only for the Lid-Ease Simplex strainer line.

② Source: Parker O-Ring Handbook (except for PTFE (Derivative) Encapsulated).

TROUBLESHOOTING

PROBLEM	POSSIBLE CAUSE	SOLUTIONS
The Lid is difficult to turn	1) The system is under pressure	1) Relieve the pressure
	2) The o-ring is swollen	2) Check compatibility of the o-ring with the fluid and temperature.
	3) The fluid inside is sticky or solid	3) a) Remove the lid before liquid solidifies b) May require heat tape and insulation around body
The lid is difficult to install	4) The o-ring is swollen	4) Replace with a new o-ring, or a different, more compatible o-ring material
	5) The o-ring is not lubricated	5) Lubricate the o-ring with grease or a suitable lubricant
	6) There is too much fluid in the body	6) Drain out the fluid, leaving more air in the body before installing the lid
Fluid leaks around the top of the strainer	7) The o-ring is cut	7) Replace the o-ring (never try to install a cut o-ring)
	8) There is foreign material under the o-ring	8) Remove & clean the o-ring, groove in lid, & body o-ring seat. Reinstall, making sure to lubricate the o-ring
	9) The o-ring has shrunk	9) Select a compatible o-ring material
There is excessive pressure drop	10) The basket is filled with contaminants	10) Clean the basket more frequently
	11) The basket mesh is too fine	11) Check the pressure drop curves. A larger strainer or a larger mesh basket may be required
	12) The viscosity is too high	12) Increase the strainer unit size or use a larger mesh basket.

VIKING PUMP

WARRANTY

Viking pumps, strainers and reducers are warranted to be free of defects in material and workmanship under normal conditions of use and service. The warranty period varies by type of product. A Viking product that fails during its warranty period under normal conditions of use and service due to a defect in material or workmanship will be repaired or replaced by Viking. At Viking's sole option, Viking may refund (in cash or by credit) the purchase price paid to it for a Viking product (less a reasonable allowance for the period of use) in lieu of repair or replacement of such Viking product. Viking's warranty is subject to certain restrictions, limitations, exclusions and exceptions. A complete copy of Viking's warranty, including warranty periods and applicable restrictions, limitations, exclusions and exceptions, is posted on Viking's website (www.vikingpump.com/warranty/warranty-info). A complete copy of the warranty may also be obtained by contacting Viking through regular mail at Viking Pump, Inc., 406 State Street, Cedar Falls, Iowa 50613, USA.

THIS WARRANTY IS AND SHALL BE VIKING'S SOLE AND EXCLUSIVE WARRANTY AND IS IN LIEU OF ALL OTHER WARRANTIES, EXPRESS OR IMPLIED, INCLUDING, BUT NOT LIMITED TO, ALL WARRANTIES OF MERCHANTABILITY, FITNESS FOR A PARTICULAR PURPOSE AND NON-INFRINGEMENT, ALL OF WHICH OTHER WARRANTIES ARE EXPRESSLY EXCLUDED.

THE RIGHTS AND REMEDIES UNDER THIS WARRANTY ARE AND SHALL BE THE SOLE AND EXCLUSIVE RIGHTS AND REMEDIES AGAINST VIKING. EXCEPT FOR THE SPECIFIC LIABILITIES AND OBLIGATIONS PROVIDED UNDER THIS WARRANTY, VIKING SHALL HAVE NO LIABILITY OR OBLIGATION WITH RESPECT TO ANY PRODUCT CLAIMED TO BE DEFECTIVE IN ANY MANNER.

UNDER NO CIRCUMSTANCES SHALL VIKING BE LIABLE UNDER THIS WARRANTY OR OTHERWISE FOR SPECIAL, INCIDENTAL, INDIRECT, CONSEQUENTIAL OR PUNITIVE DAMAGES OF ANY KIND, INCLUDING, BUT NOT LIMITED TO, LOST OR UNREALIZED SALES, REVENUES, PROFITS, INCOME, COST SAVINGS OR BUSINESS, LOST OR UNREALIZED CONTRACTS, LOSS OF GOODWILL, DAMAGE TO REPUTATION, LOSS OF PROPERTY, LOSS OF INFORMATION OR DATA, LOSS OF PRODUCTION, DOWNTIME, OR INCREASED COSTS, IN CONNECTION WITH ANY PRODUCT, EVEN IF VIKING HAS BEEN ADVISED OR PLACED ON NOTICE OF THE POSSIBILITY OF SUCH DAMAGES AND NOTWITHSTANDING THE FAILURE OF ANY ESSENTIAL PURPOSE OF ANY PRODUCT.