

The "ESSENTIAL" component in your chemical tanker system



CE



The "ESSENTIAL" component in your chemical tanker system

For too long, **cast iron pumps have compromised the integrity** of chemicals carried in stainless steel road tankers. Designed specifically for the chemical transport industry, the Wright Flow RTPe stainless steel pump delivers that essential missing component. Better yet, it provides a **cost-effective solution** to this problem, while still **outperforming the competition** in both speed and reliability.

Based on the industry-leading hygienic RTP, the RTPe incorporates **all of the features your chemical tanker needs**, while eliminating those that it does not.

Protect your investment and make your chemical transport business even stronger. The RTPe is the **essential component** to complete your chemical tanker system.

NOT SURE WHICH PUMP YOU NEED?

YOUR NEEDS	WRIGHT FLOW RTPe	WRIGHT FLOW RTP	COMPETITOR STAINLESS	COMPETITOR CAST IRON
All 316L Stainless Steel Wet End	✓	✓	✓	✗
Low Cost	✓	✗	✗	✓
Dry-Run Capable Seals	✓	✓	✗	✗
Bi-Directional Pump as Standard	✓	✓	✓	✗
Ultra-Compact Bi-Directional Relief Valve	✓	✗	✗	✗
Designed Specifically for Tank Truck Trailers	✓	✓	✓	✗
Speeds to 1000 rpm	✓	✓	✗	✗
Ingress Protected & Sealed Maintenance-Free Gearbox	✓	✓	✗	✗
Solids Handling	✓	✓	✗	✗
Zero Product Contamination from Rotors	✓	✓	✓	✗
Easy Mount Adapter Plate Available	✓	✗	✗	✗

✓ Yes ✗ No/Not Ideal or Limitations



The performance you need at a cost-effective price

FEATURES & OPTIONS

- 316L stainless steel wet end construction
- Choice of mechanical seal or dry-run capable composite o-ring
- Drop-in foot and pipework to common cast iron alternatives
- Ingress protected and sealed maintenance-free gearbox
- ASA150 flange bolting pattern
- Low weight
- SAE-A 2 or 4 bolt hydraulic drive
- Ultra-compact bi-directional internal relief valve
- FFKM/PTFE or FKM elastomers
- Other port options available

PERFORMANCE

- Wide range of chemical compatibility
- Efficiently handles both low and high viscosity liquids with improved pressure capabilities for faster loading and unloading
- Excellent displacement / weight ratios, which means more in the tank and less in the cabinet
- Precision helical gears, rotors and shaft design, with optimized bearing position, minimize overhung load – extending seal & bearing life

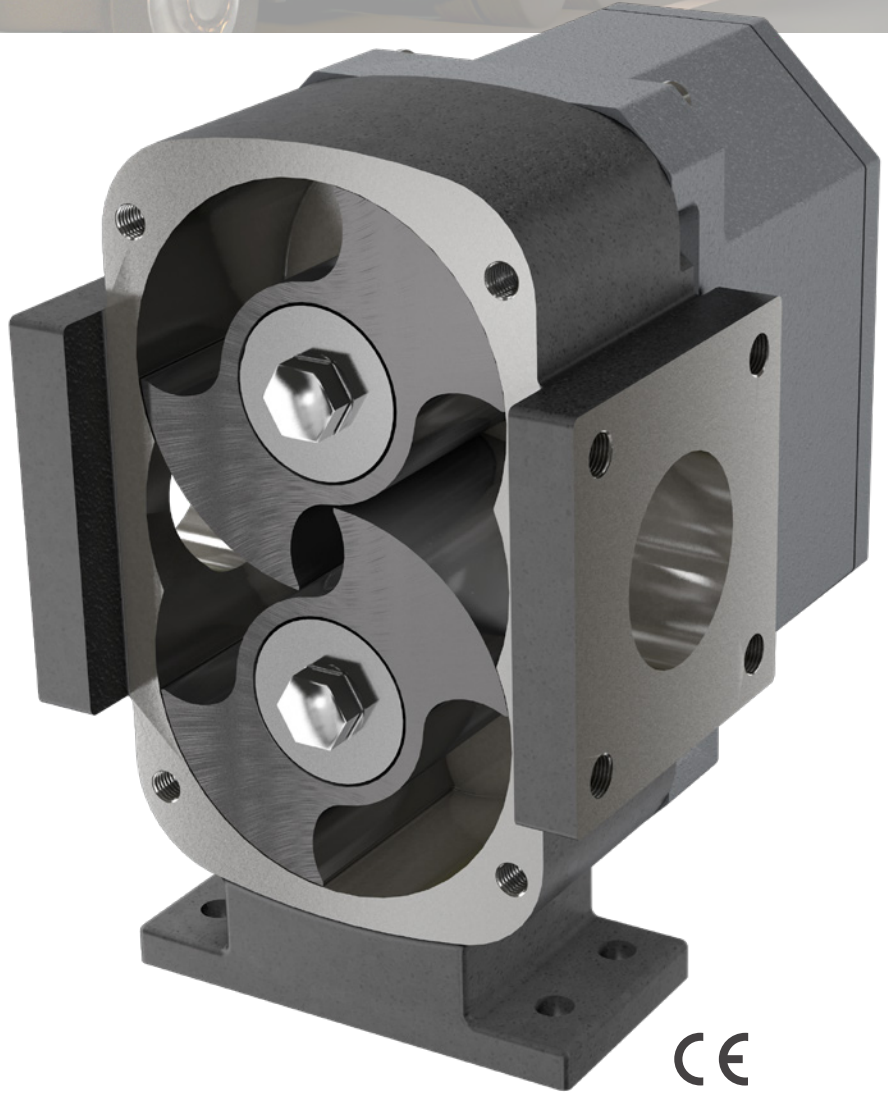

PERFORMANCE RANGE:

CAPACITY	to 60 m ³ /hr / 264 USGPM
PRESSURE	to 10 BAR / 145 PSI
VISCOSITY	to 200,000 cSt / 910,000 SSU
TEMPERATURE	to 110°C / 230°F
DISPLACEMENT	1 l/rev. / 0.264 USG/rev.

RTPe

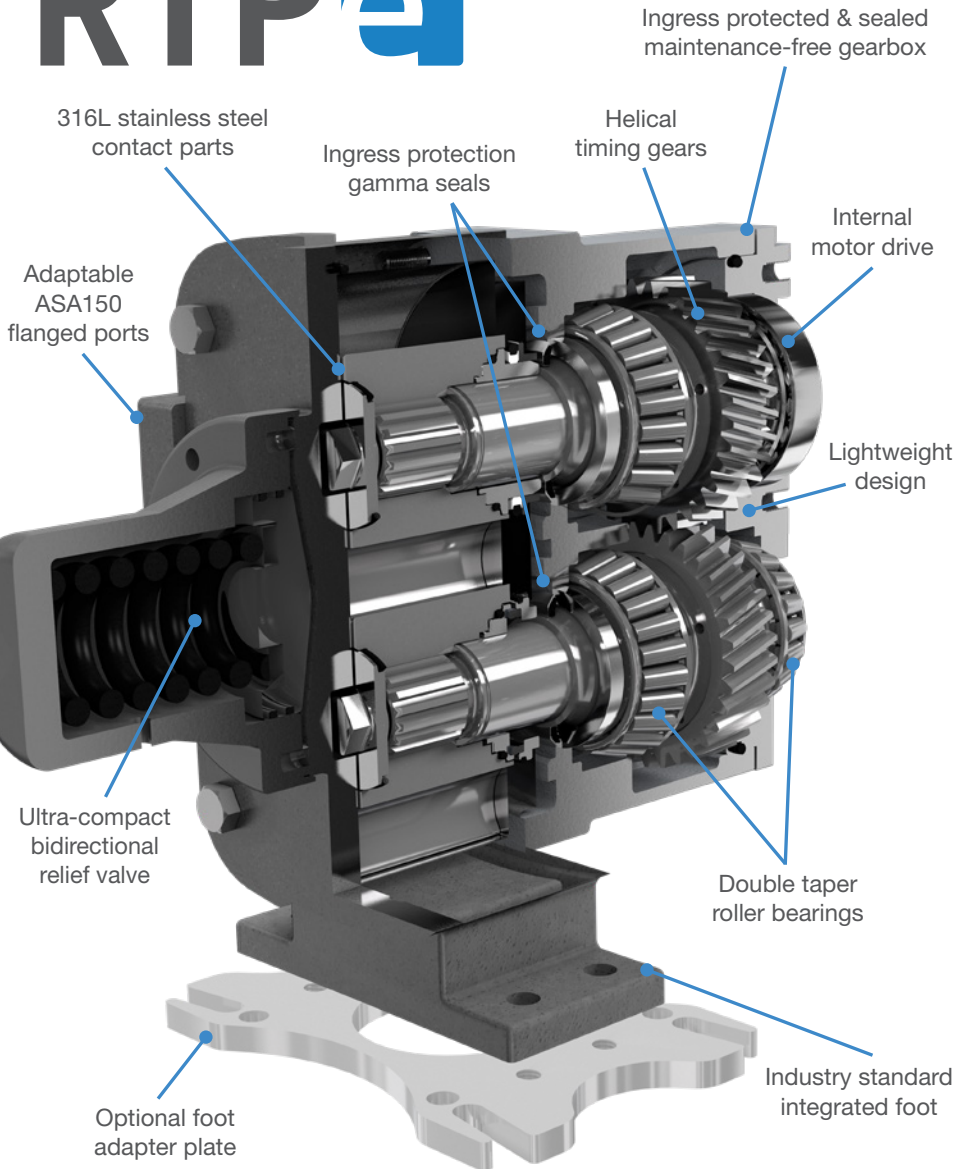

CLEANABILITY

- The simple design behind the rotor makes strip cleaning easy and fast
- Choose the cleaning process that fits your needs: COP (Clean Out of Place) or CIP (Clean In Place)

EASE OF MAINTENANCE

- Innovative front loading seal design enables quick inspection and easy servicing
- Sealed gearbox with long-life lubrication eliminates oil inspection and filling
- Easy to service design requires no special tools for disassembly and eliminates need for end clearance adjustments

MAINTENANCE KITS:

- Everything you need in one place
- Reduce frequency of repairs
- Increase service life
- Increase uptime
- Save time and money
- Kits include exploded diagram and parts list
- Seal, bearing and elastomer kits available

WATCH THE VIDEO & LEARN MORE AT: WRIGHTFLOWTECHNOLOGIES.COM/RTPe

AMERICAS:

WRIGHT FLOW TECHNOLOGIES, INC.

406 State Street
Cedar Falls, IA 50613 USA
Phone: (319) 268-8013
E-mail: wright.usa@idexcorp.com

EUROPE & ASIA:

WRIGHT FLOW TECHNOLOGIES LTD.

Highfield Industrial Estate
Edison Road Eastbourne
East Sussex, United Kingdom, BN23 6PT
Phone: +44(0) 1323 509211
E-mail: wright.eu@idexcorp.com

FOR MORE INFORMATION, CONTACT YOUR LOCAL AUTHORIZED
WRIGHT FLOW TECHNOLOGIES DISTRIBUTOR AT:

