

**PARTS & ACCESSORIES:
HELICAL GEAR REDUCERS
SIZES A, B & C**

Section	610
Page	610.1
Issue	L

Gear Ratio Range: (varies by reducer size)	1.87:1 to 7.95:1
Output Speeds (with 1750 rpm input)	950 to 220 rpm
Reducer Horsepower Range:	1.4 HP (.1 kW) to 49.8 HP (37.2 kW)

THREE SIZES AVAILABLE

Viking's helical gear reducers are available in three basic sizes, each size offering several gear ratios.

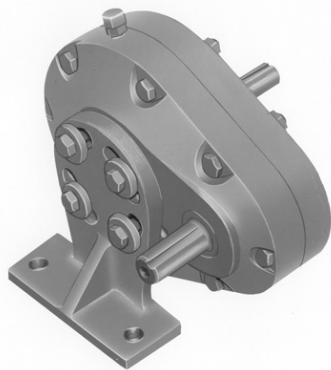

"A" Size Reducer
(mounting bracket on input side)

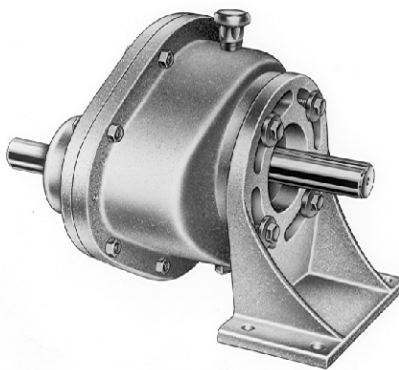

"B" Size Reducer
(mounting bracket on output side)

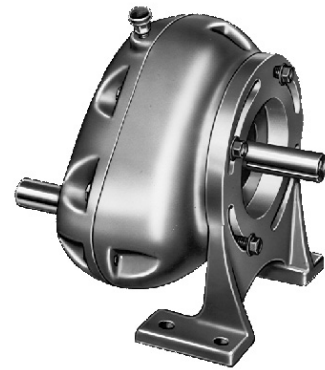

"C" Size Reducer
(mounting bracket on output side)

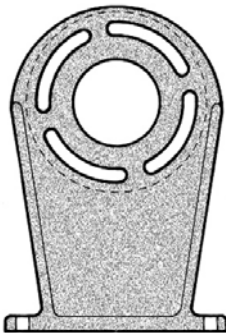

Universal Mounting

Each size has one or more mounting brackets which match the reducer's output (slow speed) shaft height to the drive shaft height on one or more Viking pumps. Adjustment slots on the brackets allow you to swivel the reducer's input (high speed) shaft height to adapt to a variety of motors or other prime movers. These mounting brackets assure no radial load on the reducer, drive or driven shafts.

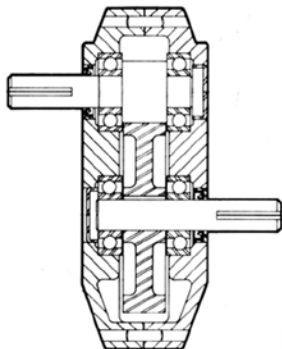

Simple, Robust Design

All ratios are fully interchangeable in each gearbox. All three reducers contain a hardened steel pinion and gear supported by precision ball bearings.

Section	610
Page	610.2
Issue	L

**PARTS & ACCESSORIES:
HELICAL GEAR REDUCERS
SIZES A, B & C**

SELECTING THE CORRECT VIKING HELICAL GEAR REDUCER

1. Determine the actual horsepower requirements of the application from the pump curve or specifications for other driven equipment.
2. Determine the “equivalent horsepower” for the application by multiplying the actual horsepower to be transmitted by the appropriate service factor, which can be obtained from the Service Factor Table on page 4. This service factor takes into account the length of service per day, the load classification (uniform, moderate shock, heavy shock), and the type of drive. A table of driven load classifications is included to help you determine the service factor to use.
3. Find the reducer from the Horsepower Tables on pages 4 and 5 which most closely matches your speed requirements. Make sure the equivalent horsepower (kW) for a given input speed and ratio is less than or equal to the maximum recommended horsepower (kW) shown in the chart on the “MAXIMUM REDUCER HP / KW” lines.
4. Select the correct reducer bracket to match the driven load’s shaft height. For Viking Pumps, refer to the table “Shaft Center Height for Common Viking Pumps” on the following page, but always verify shaft height on the actual pump’s dimensional drawing. For certain pumps, a set of Pump and Reducer Mounting Pads are required to match the pump shaft height to the reducer shaft height, as listed below:
 - For General Purpose “L,” “LQ” and “LL” pumps with 6” shaft height, use Pump and Reducer Mounting Pads, Part No. 2-773-008-200 (2-Req’d) under the 5-1/2” reducer bracket for “B” reducer units.
 - For Heavy Duty “L,” “LQ,” “LL” and “LS” pumps with 7” shaft height, use Pump and Reducer Mounting Pads, Part No. 2-773-011-200 (2-Req’d) under the pump, and the 7-3/4” reducer bracket for “C” reducer units.
 - For “Q” and “QS” Heavy Duty pumps with 8-3/4” shaft height, use Pump and Reducer Mounting Pads, Part No. 2-773-010-200 (2-Req’d) under the 7-3/4” reducer bracket for “C” reducer units.
 - For “M” Heavy Duty pumps with 10” shaft height, use Pump and Reducer Mounting Pads, Part No. 2-773-009-200 (2-Req’d), and the 9-1/2” reducer bracket for “C” reducer units.
5. Check the Specifications table to ensure that the shaft center height of your driver falls within the Input Shaft Center Height Min / Max range.

Example:

A Viking K124A requires a 7 HP driver at 420 rpm to deliver the desired output of 40 gpm at 200 psi on 100 SSU fluid (from the pump curve), and is driven 24 hours per day. Using the Service Factor table, multiply the service factor (in this case, 1.25) times the horsepower required (7 HP) for a reducer horsepower requirement of 8.75 HP.

Looking at the Specifications Table, using a 1750 rpm motor, the desired 420 RPM output speed requires a reducer gear ratio of about 4.2:1. Reviewing the Horsepower tables, the “A” size reducer’s Maximum Reducer HP at 3.1 is insufficient. The “B” size reducer offers a Maximum Reducer HP of 11 HP, which exceeds the 8.75 HP required, so select the “B” reducer with 4.19:1 ratio, P/N 3-551-003-419.

Because the pump has a 5-1/2” shaft height, select the “B” reducer bracket with matching output shaft height, P/N 2-074-008-100. Check that the driver shaft height is within the min/max input shaft height range (2.12” to 8.88”) of this reducer bracket. The selected driver, a 213T frame motor with 5-1/4” shaft height, is within the allowable range.

PARTS & ACCESSORIES: HELICAL GEAR REDUCERS

SIZES A, B & C

Section	610
Page	610.3
Issue	L

SPECIFICATIONS: HELICAL GEAR REDUCERS AND BRACKETS

Reducer Size	Viking Reducer Part No.	Gear Ratio	Output Speeds (RPM)				Approx. Shipping Wt. (lbs./ Kg)	1 Viking Reducer Bracket Part No.	Output Shaft Center Height (In.)	Approx. Shipping Wt. (lbs./ Kg)
			@ 950 RPM Input	@ 1450 RPM Input	@1150 RPM Input	@1750 RPM Input				
A	3-551-049-224	2.24:1	420	640	520	780	21 / 9.5	2-074-020-100	3-1/2	6 / 2.7
	3-551-050-276	2.76:1	350	520	420	640				
	3-551-051-343	3.43:1	280	420	350	520				
	3-551-052-417	4.17:1	230	350	280	420				
B	3-551-054-187	1.87:1	520	780	640	950	37 / 16.8	2-074-010-100	4-5/8	9 / 4.1
	3-551-055-224	2.24:1	420	640	520	780				
	3-551-001-276	2.76:1	350	520	420	640		2-074-008-100	5-1/2	10 / 4.5
	3-551-002-340	3.40:1	280	420	350	520				
	3-551-003-419	4.19:1	230	350	280	420		2-074-007-100	7	11 / 5.0
	3-551-004-506	5.06:1	190	280	230	350				
	3-551-005-627	6.27:1	155	230	190	280				
	3-551-007-765	7.65:1	125	190	155	230				
C	3-551-056-221	2.21:1	420	640	520	780	94 / 42.6	2-074-011-100	7-3/4	19 / 8.6
	3-551-032-280	2.80:1	350	520	420	640				
	3-551-008-331	3.31:1	280	420	350	520				
	3-551-009-421	4.21:1	230	350	280	420		2-074-012-100	9-1/2	24 / 10.9
	3-551-010-508	5.08:1	190	280	230	350				
	3-551-011-624	6.24:1	155	230	190	280				
	3-551-012-795	7.95:1	120	180	145	220				

- Any "B" size reducer bracket may be used with any "B" size reducer, and any "C" size reducer bracket may be used with any "C" size reducer.
- Shows adjustment range of input (high speed) shaft, allowing the gear reducer to be matched to various drivers. Range will change when using Pump and Reducer Mounting Pads.

SHAFT CENTER HEIGHT FOR COMMON VIKING PUMPS

Pump Size	Shaft Centerline Height (inches)	
	Series 32, 432, 34	Series 124A/AE/E, 4124A/AE/B, 224A, 4224A/B, 324A, 4324A, 8124A, 4624B, 4924A, 123A, 4123A, 223A, 4223A, 323A, 4323A, 8123A, 127A, 4127A, 227A, 4227A, 327A, 4327A, 8127A, 157B, 4157B, 257B, 4257B, 724, 4724, 126A, 4126A, 226A, 4226A
C, F, FH	1-5/8	
G, GG	2-3/4	2-3/41
H, HJ, HL	2-3/4	3-1/2
AS, AK, AL		5-1/4
K, KK	4-5/8	5-1/2
L, LQ, LL, LS	6	7
Q, QS	7-3/4	8-3/4
M	9-1/2	10
N	9-1/2	9-1/2
R, RS		13-1/4

- G724 and G4724 are 2"

Section	610
Page	610.4
Issue	L

PARTS & ACCESSORIES: HELICAL GEAR REDUCERS SIZES A, B & C

SERVICE FACTOR TABLE

POWER SOURCE 1,3	CLASSIFICATION OF DRIVEN LOAD 2,3	INTERMITTENT UP TO 3 HOURS PER DAY	8 TO 10 HOURS PER DAY	24 HOURS PER DAY
Electric Motor, Steam Turbine, or Hydraulic Motor	Uniform	0.8	1.0	1.25
	Moderate Shock	1.0	1.25	1.5
	Heavy Shock	1.5	1.75	2.0
MULTI-CYLINDER Internal Combustion Engine	Uniform	1.0	1.25	1.5
	Moderate Shock	1.25	1.5	1.75
	Heavy Shock	1.75	2.0	2.25

1. For applications driven by single cylinder engines, refer to factory for other service factors.
2. Rotary Pump applications are classified as Uniform Loads.
3. Use of belt or chain type drives to either reducer input or output shaft is not recommended.

DRIVEN LOAD CLASSIFICATIONS

(Excerpted from AGMA Information Sheet 922-A96 ©1996)

Key: U = Uniform Load; M = Moderate Shock; H = Heavy Shock

APPLICATION	LOAD CLASSIFICATION	APPLICATION	LOAD CLASSIFICATION
Pumps, Rotary and Centrifugal	U	Fans, Cooling Tower	M
Pumps, Reciprocating	M	Feeders, Apron, Belt, Screw	U
Agitators	U	Feeders, Reciprocating	M
Blowers	U	Generators	U
Compressors, Centrifugal & Lobe	U	Hammer Mills	M
Compressors, Reciprocating	M	Machine Tools	M
Cranes and Hoists	M	Mills, Rotary	M
Crushers, Ore and Stone	H	Mixers, Concrete, Drum Type	M
Elevators	M	Printing Presses	U
Fans, Centrifugal, Forced Draft	U	Sewage Disposal Bar Screens	U

VIKING "A" SIZE HELICAL REDUCER HORSEPOWER TABLE

HIGH SPEED SHAFT INPUT RPM 1	VIKING GEAR REDUCER RATIOS "A" SIZE				
	2.24 to 1	2.76 to 1	3.43 to 1	4.17 to 1	
1750	780	640	520	420	Low Speed Shaft RPM
	6.1 / 4.6	4.9 / 3.7	3.8 / 2.8	3.1 / 2.3	Maximum Reducer HP / KW
1450	640	520	420	350	Low Speed Shaft RPM
	5.2 / 3.9	4.2 / 3.1	3.2 / 2.4	2.7 / 2.0	Maximum Reducer HP / KW
1150	520	420	350	280	Low Speed Shaft RPM
	4.3 / 3.2	3.4 / 2.5	2.6 / 1.9	2.2 / 1.6	Maximum Reducer HP / KW
950	420	350	280	230	Low Speed Shaft RPM
	3.6 / 2.7	2.9 / 2.2	2.2 / 1.6	1.8 / 1.3	Maximum Reducer HP / KW
870	390	320	260	210	Low Speed Shaft RPM
	3.3 / 2.5	2.7 / 2.0	2.0 / 1.5	1.7 / 1.3	Maximum Reducer HP / KW
720	320	260	210	175	Low Speed Shaft RPM
	2.8 / 2.1	2.2 / 1.6	1.7 / 1.3	1.4 / 1.0	Maximum Reducer HP / KW

PARTS & ACCESSORIES:
HELICAL GEAR REDUCERS
 SIZES A, B & C

Section	610
Page	610.5
Issue	L

VIKING “B” SIZE HELICAL REDUCER HORSEPOWER TABLE

HIGH SPEED SHAFT INPUT RPM ¹	VIKING GEAR REDUCER RATIOS “B” SIZE								
	1.87 to 1	2.24 to 1	2.76 to 1	3.40 to 1	4.19 to 1	5.06 to 1	6.27 to 1	7.65 to 1	
1750	950	780	640	520	420	350	280	230	Low Speed Shaft RPM
	19.0 / 14.2	17.0 / 12.7	15.0 / 11.2	13.0 / 9.7	11.0 / 8.2	9.5 / 7.1	7.6 / 5.7	6.4 / 4.8	Maximum Reducer HP / KW
1450	780	640	520	420	350	280	230	190	Low Speed Shaft RPM
	17.3 / 12.9	15.5 / 11.6	13.4 / 10.0	11.6 / 8.7	9.9 / 7.4	8.5 / 6.3	6.4 / 4.8	5.4 / 4.0	Maximum Reducer HP / KW
1150	640	520	420	350	280	230	190	155	Low Speed Shaft RPM
	16.5 / 12.3	14.0 / 10.4	11.6 / 8.7	10.1 / 7.5	8.5 / 6.3	7.3 / 5.4	5.3 / 4.0	4.4 / 3.3	Maximum Reducer HP / KW
950	520	420	350	280	230	190	155	125	Low Speed Shaft RPM
	15.5 / 11.6	12.8 / 9.5	10.1 / 7.5	9.0 / 6.7	7.6 / 5.7	6.0 / 4.5	4.3 / 3.2	3.7 / 2.8	Maximum Reducer HP / KW
870	470	390	320	260	210	175	140	115	Low Speed Shaft RPM
	13.7 / 10.2	11.3 / 8.4	9.3 / 6.9	8.5 / 6.3	7.2 / 5.4	5.6 / 4.2	4.0 / 3.0	3.4 / 2.5	Maximum Reducer HP / KW
720	390	320	260	210	175	140	115	95	Low Speed Shaft RPM
	11.7 / 8.7	9.6 / 7.2	7.8 / 5.8	7.5 / 5.6	6.1 / 4.6	4.7 / 3.5	3.4 / 2.5	2.8 / 2.1	Maximum Reducer HP / KW

VIKING “C” SIZE HELICAL REDUCER HORSEPOWER TABLE

HIGH SPEED SHAFT INPUT RPM ¹	VIKING GEAR REDUCER RATIOS “C” SIZE							
	2.21 to 1	2.80 to 1	3.31 to 1	4.21 to 1	5.08 to 1	6.24 to 1	7.95 to 1	
1750	780	640	520	420	350	280	220	Low Speed Shaft RPM
	49.8 / 37.2	43.5 / 32.5	39.0 / 29.1	32.4 / 24.2	26.6 / 19.8	19.7 / 14.7	18.0 / 13.4	Maximum Reducer HP / KW
1450	640	520	420	350	280	230	180	Low Speed Shaft RPM
	45.3 / 33.8	36.6 / 27.3	32.8 / 24.6	27.2 / 20.3	22.3 / 16.6	16.7 / 12.5	15.2 / 11.3	Maximum Reducer HP / KW
1150	520	420	350	280	230	190	145	Low Speed Shaft RPM
	40.1 / 29.9	30.0 / 22.4	26.8 / 20.0	22.2 / 16.6	18.2 / 13.6	13.8 / 10.3	12.6 / 9.4	Maximum Reducer HP / KW
950	420	350	280	230	190	155	120	Low Speed Shaft RPM
	29.1 / 21.7	24.7 / 18.4	22.1 / 16.5	18.3 / 13.7	15.0 / 11.2	11.4 / 8.5	10.4 / 7.8	Maximum Reducer HP / KW
870	400	320	260	215	175	140	110	Low Speed Shaft RPM
	28.4 / 21.2	22.7 / 16.9	20.3 / 15.1	16.8 / 12.5	13.8 / 10.3	10.6 / 7.9	9.6 / 7.2	Maximum Reducer HP / KW
720	330	260	215	175	140	115	90	Low Speed Shaft RPM
	24.1 / 18.0	19.0 / 14.2	17.0 / 12.7	14.1 / 10.5	11.5 / 8.6	8.9 / 6.6	8.1 / 6.0	Maximum Reducer HP / KW

1. For input speeds higher than 1750 RPM, consult the factory.

Section	610
Page	610.6
Issue	L

**PARTS & ACCESSORIES:
HELICAL GEAR REDUCERS
SIZES A, B & C**

DIMENSIONS "A" SIZE REDUCER BRACKET

NOTE: VIKING BRACKET MOUNTS ON OUTPUT SHAFT SIDE OF REDUCER. HOLES ARE DRILLED IN BOTH SIDES OF REDUCER.

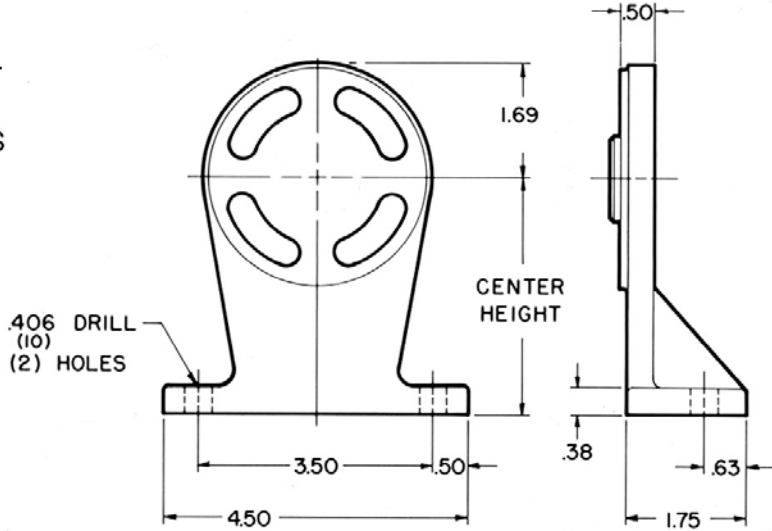

VIKING NUMBER	CENTER HEIGHT
2-074-020-100	3.50

DIMENSIONS "A" SIZE VIKING HELICAL GEAR REDUCER

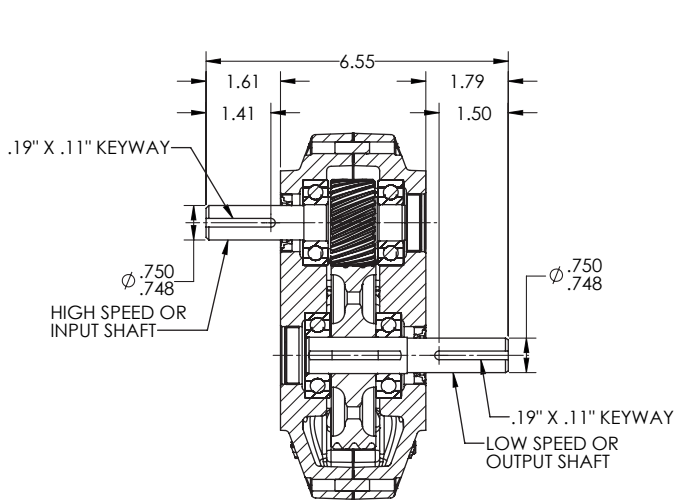

SECTION A-A

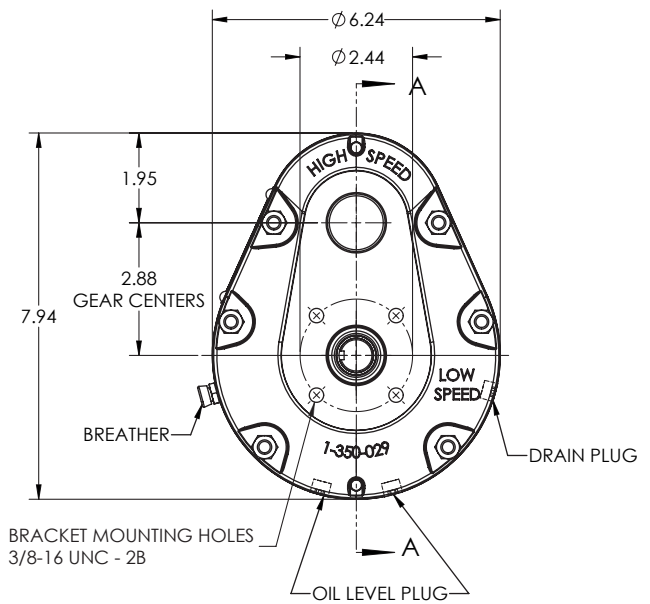

PARTS & ACCESSORIES:
HELICAL GEAR REDUCERS
 SIZES A, B & C

Section	610
Page	610.7
Issue	L

DIMENSIONS "B" SIZE REDUCER BRACKET

"B" SIZE BRACKET

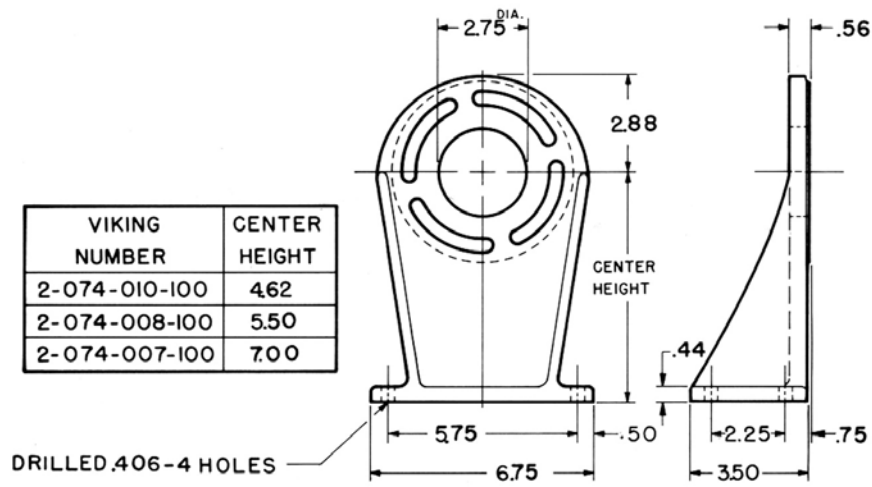

DIMENSIONS "B" SIZE VIKING HELICAL GEAR REDUCER

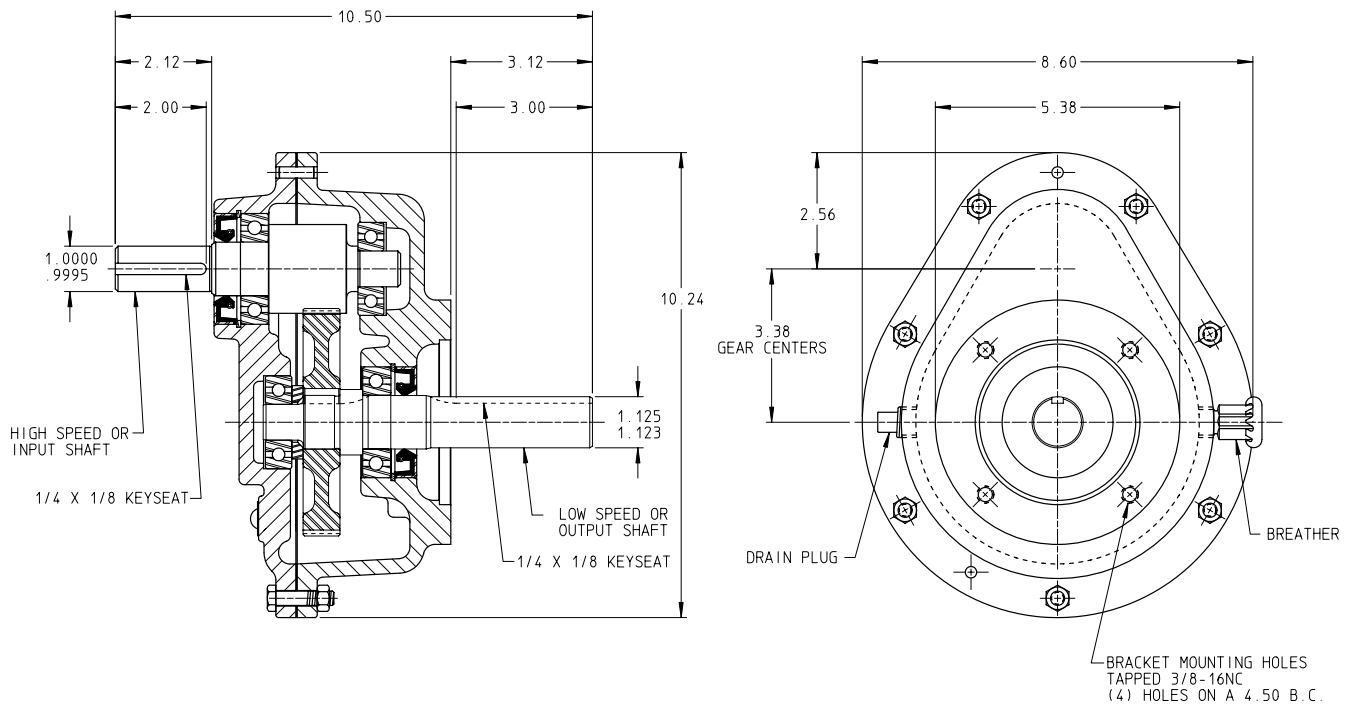

Section	610
Page	610.8
Issue	L

**PARTS & ACCESSORIES:
HELICAL GEAR REDUCERS
SIZES A, B & C**

DIMENSIONS "C" SIZE REDUCER BRACKET

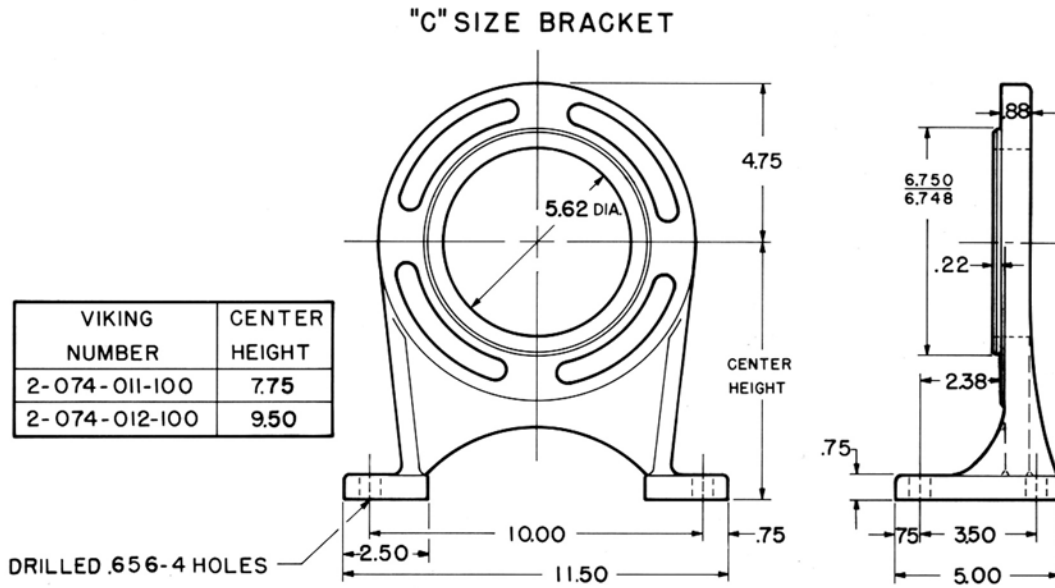

DIMENSIONS "C" SIZE VIKING HELICAL GEAR REDUCER

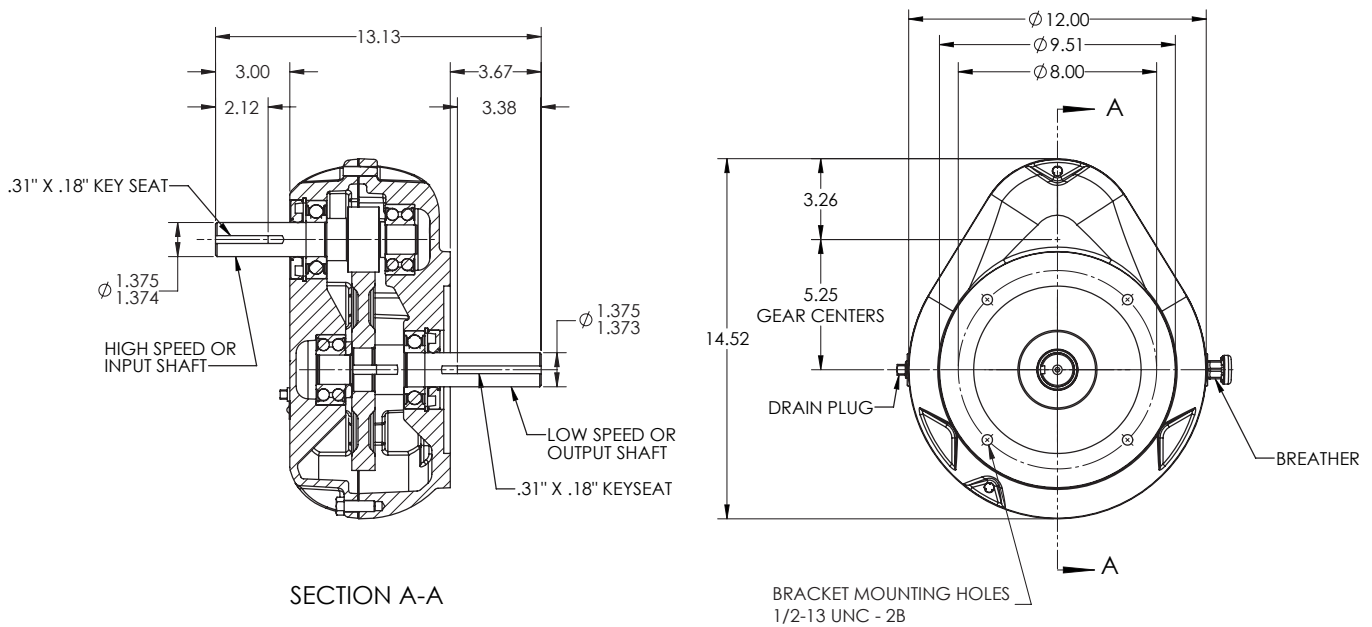

**PARTS & ACCESSORIES:
HELICAL GEAR REDUCERS**

SIZES A, B & C

Section	610
Page	610.9
Issue	L

INPUT SHAFT CENTER HEIGHT MIN/MAX

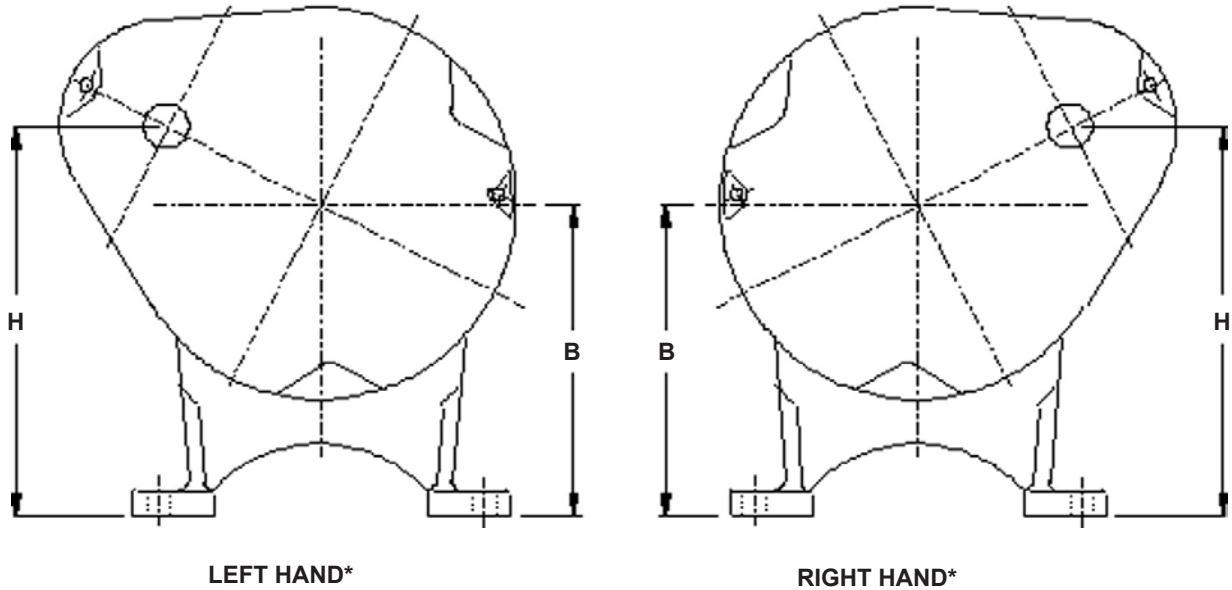

*Viewed from input shaft end

B – Output shaft center height (Centerline of mounting bracket)

H – Input shaft center height

Size	Mounting Bracket Part No.	Output Shaft Center Height [in.]	Left Hand		Right Hand	
			Input Shaft Center Height [in.]		Input Shaft Center Height [in.]	
			Max.	Min.	Max.	Min.
A	2-074-020-100	3-1/2	4-1/2	2-3/8	4-1/2	2-3/8
B	2-074-010-100	4-5/8	6-1/8	2-5/8	6-5/8	3-1/8
	2-074-008-100	5-1/2	7-1/8	3-5/8	7-3/8	3-7/8
	2-074-007-100	7	9-3/8	6	8	4-5/8
C	2-074-011-100	7-3/4	10-1/2	5-1/2	10	5
	2-074-012-100	9-1/2	12-1/8	7-1/4	11-3/4	6-3/4

Section	610
Page	610.10
Issue	L

**PARTS & ACCESSORIES:
HELICAL GEAR REDUCERS
SIZES A, B & C**

APPLICATION DATA SHEET

COMPANY _____ DATE _____

NAME _____ TITLE _____

ADDRESS _____ CITY _____ STATE _____

COUNTRY _____ POSTAL CODE _____

PHONE _____ FAX _____ EMAIL _____

PRIME MOVER

() Electric Motor; () Gasoline Engine; () Diesel Engine; () Steam Engine; () Turbine;

Number of Cylinders _____; Normal Operating Speed _____ RPM;

Speed Range: (Min.) _____ RPM; (Max.) _____ RPM;

Normal Rating _____ HP at _____ RPM;

Maximum Overload Capacity _____ HP at _____ RPM;

Special Features _____

DRIVEN EQUIPMENT

Description _____

Character of Load: () Smooth; () Moderate Shock; () Heavy Shock;

Daily Operating Period: () Not to exceed 3 hours; () 8 to 10 hours; () 24 hours;

Rotation: () Continuously One Direction; () Reversing Service;

Actual Starting Load _____ HP; How Frequent _____

Actual Normal Operating Load _____ HP; _____ HP at Min RPM; _____ HP at Max RPM;

Actual Max. Peak Load _____ HP; How Frequent _____

Cycle of Operation _____

Special Features, Unusual Operating Conditions (Fumes, Dust, Temperature, Moisture, etc.) _____

CONNECTION TO REDUCER

INPUT SHAFT

OUTPUT SHAFT

() Flexible Coupling _____ Type _____ Size () Flexible Coupling _____ Type _____ Size

() Chain Drive _____ Pitch Diameter () Chain Drive _____ Pitch Diameter

() V-Belt _____ Pitch Diameter () V-Belt _____ Pitch Diameter

() Flat Belt _____ Pulley O.D. () Flat Belt _____ Pulley O.D.

() Gear _____ Pitch Diameter () Gear _____ Pitch Diameter

() Number & Size Belts _____ Belt Width

SPEED REDUCER

Quantity Required _____; Size _____ "A" _____ "B" _____ "C"

Input Speed _____ RPM; Output Speed _____ RPM; Ratio Desired _____ to 1;

Mounting: () Horizontal; () Vertical, Input Shaft Up; () Vertical, Output Shaft Up;

() Other (Please describe and attach sketch) _____

Location: () Inside; () Outside; Ambient Temperature Range _____ °F / °C?

() Overhung Load on Low Speed Shaft; () Overhung Load on High Speed Shaft

_____ Desired Direction of Overhung Load (please attach sketch);

Special Features _____

COMMENTS _____
