

REVISIONS			
REV.	DESCRIPTION	ECN	DATE
A.0	1. CREATED PER E184		10/15/2015

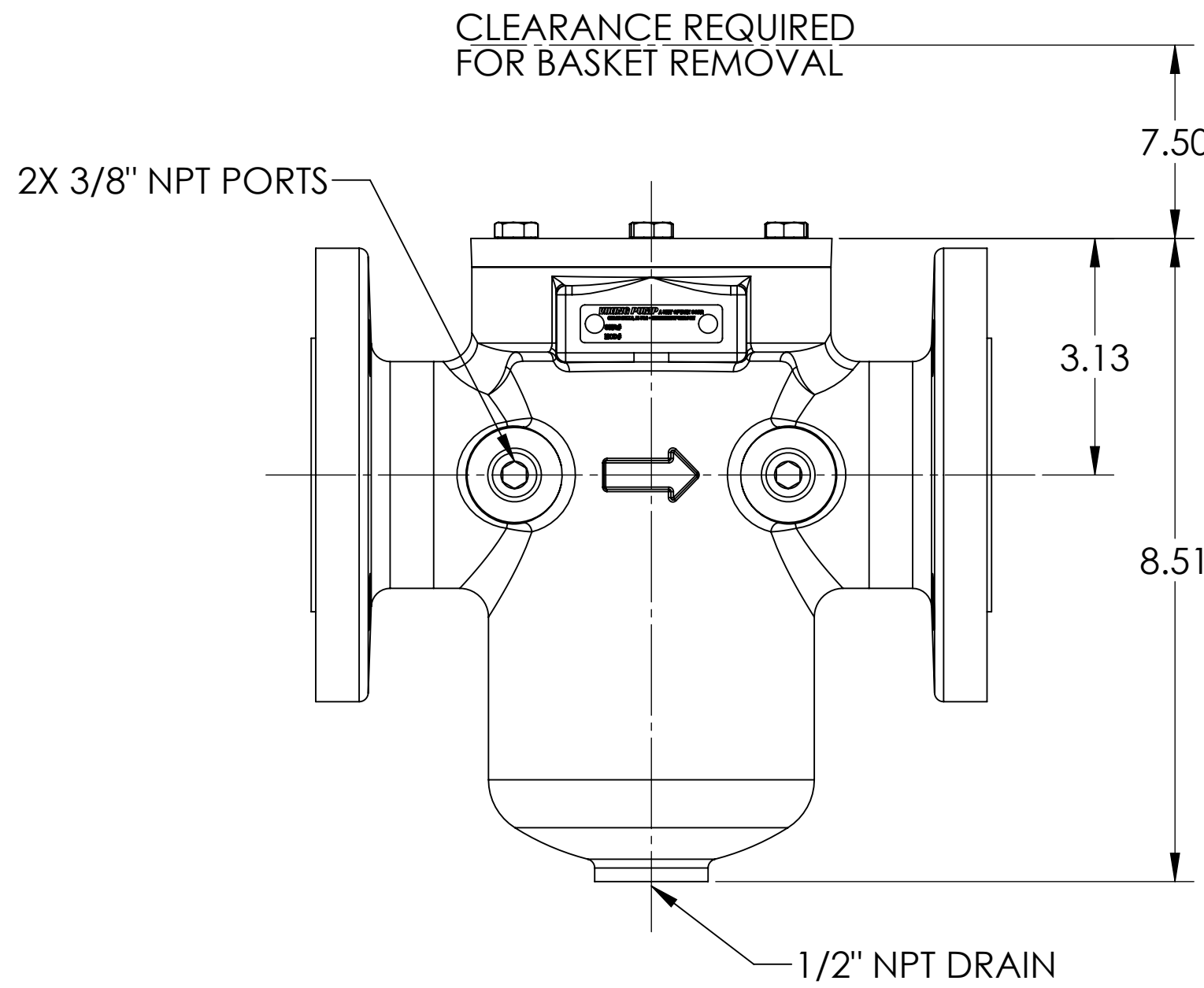

PORTS: 2" CLASS 150 RAISED FACE FLANGES - OPPOSITE

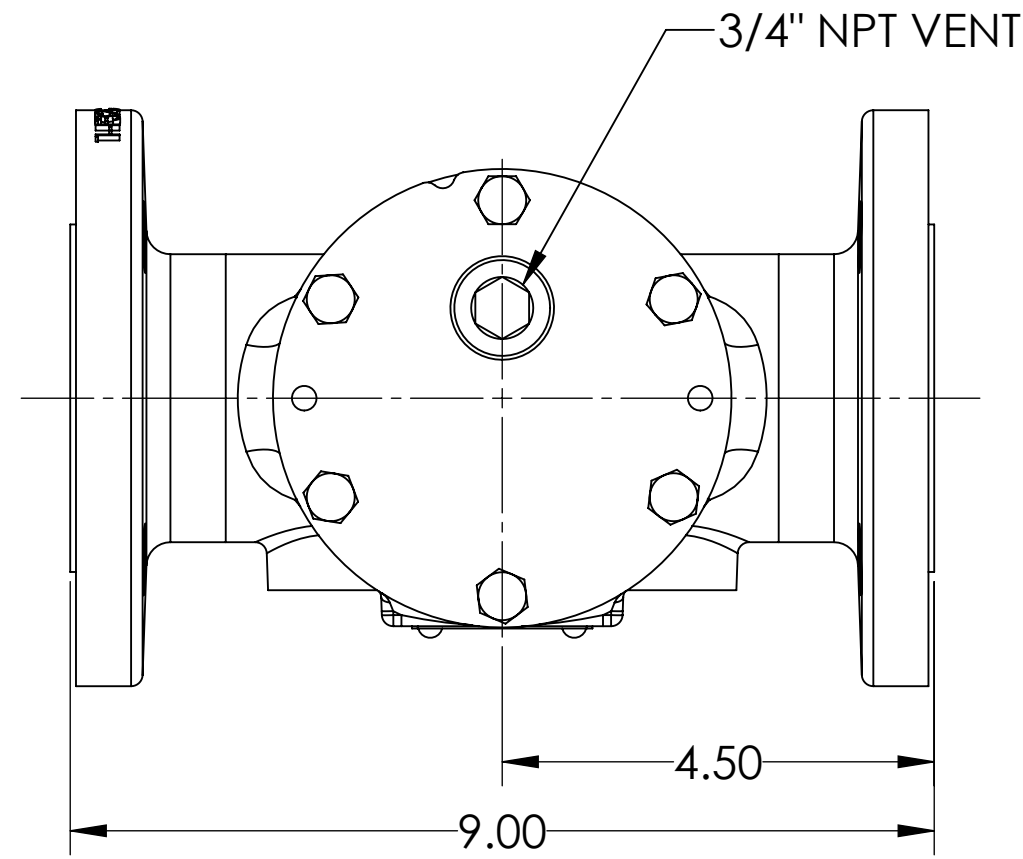
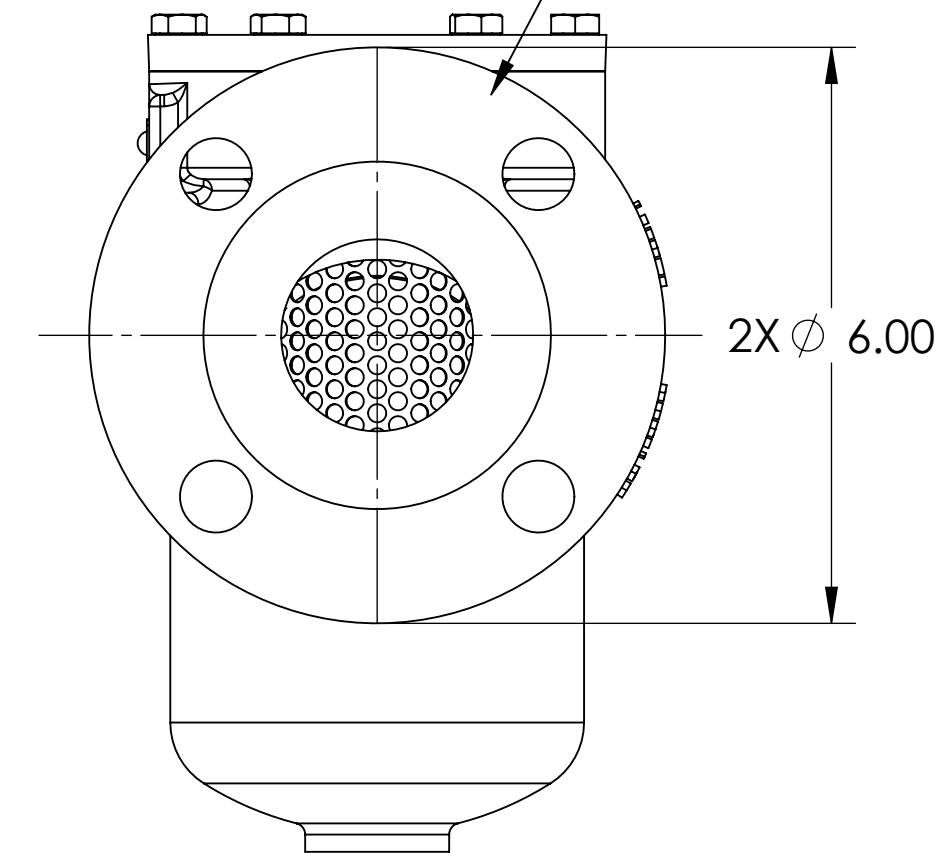

MESH	10	20	40	60	80	100
OPENING (INCHES)	.075	.034	.015	.0092	.007	.0055
OPENING (MICRONS)	1910	860	380	230	190	140

USE AND RELATED INFORMATION

MATERIAL:
SEE PARTS FOR MATERIAL SPEC

WAS:

UNLESS OTHERWISE SPECIFIED
DIMENSIONS ARE IN **INCHES**.

INTERPRET DIM AND TOLERANCES PER VIKING PUMP ES-47
BREAK EDGES .005-.015 RADIUS OR CHAMFER
.XX ±.02 .XXX ±.005 ANGLES ±1°

ALL FINISHED SURFACES ∇_{250} (AA $\frac{.030}{\text{CUTOFF}}$)

ACCEPTABILITY OF SCREW THREADS SHALL BE DETERMINED BASED ON SYSTEM 21 ASME B1.3

THIRD ANGLE PROJECTION

STATE	Released	10/16/2015
DRAWN	jpierce	10/15/2015
CHECKED	JAG	10/15/2015
PROJECT E184	3D	WEIGHT: 27.41LBS
SCALE: 1:2		
CASTING NUMBER		

VIKING PUMP VIKING PUMP, INC.
A Unit of IDEX Corporation
Cedar Falls, IA 50613
U.S.A.

THIS DRAWING IS THE PROPERTY OF VIKING PUMP, INC. AND IS PROPRIETARY IN GENERAL AND DETAIL. IT SHALL NOT BE COPIED OR ITS CONTENTS REVEALED TO OUTSIDE PARTIES WITHOUT THE WRITTEN CONSENT OF VIKING PUMP, INC.

STRAINER ASSEMBLY, 2" CLASS 150 OPPOSITE FLANGED PORTS, BOLT ON LID

SIZE DWG. NO. SHEET 1 OF 1 REV
CF-1020-R A.0