

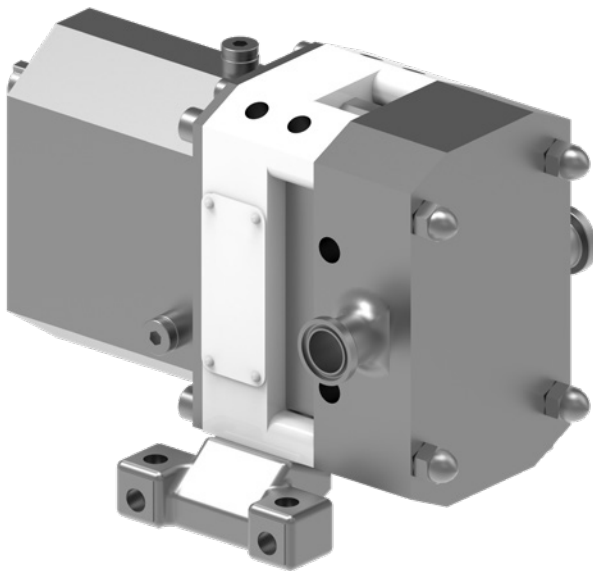

STERILOBE® SERIES™ BY WRIGHT FLOW TECHNOLOGIES
ROTARY LOBE PUMP | HYGIENIC PRODUCT LINE



FEATURES & BENEFITS

CLEANABILITY

- Cover joint profile improves hygienic characteristics & self-draining capabilities
- Clean & corrosion resistant stainless gear cover & powder coated bearing housing

EASE OF MAINTENANCE

- Front loading seals can be changed while the pump is still in-line
- Seal positioned for optimal lubrication, maximizing seal life
- Hassle free gearbox maintenance with sealed for life bearings

PERFORMANCE

- Standard bi-wing rotors offer application flexibility & good solids handling capabilities
- Multi-lobe rotors reduce shear & pulsation effect; ideal for sensitive media
- Innovative cusps with reliefs allow for easier cleaning and self draining with improved efficiency

PERFORMANCE

MODELS									
Model	Displacement		Max Pressure		Max Speed	Standard Ports		Max Capacity	
	USG/rev.	l/rev.	PSI	BAR	RPM	In	mm	GPM	m³/h
SLAS	0.0103	0.039	218	15	1400	.75	19	14	3.18
SLAL	0.0156	0.059	145	10	1400	1	25	22	5
SLBS	0.0214	0.081	218	15	1200	1	25	25.7	5.8
SLBL	0.0322	0.122	145	10	1200	1.5	38	38.7	8.8
SLCS	0.0446	0.169	218	15	1200	1.5	38	53.6	12.2
SLCL	0.0671	0.254	145	10	1200	2	50	80.5	18.3
SLDS	0.093	0.352	218	15	1000	1.5	38	93	20.5
SLDL	0.1395	0.528	145	10	1000	2	50	139.5	31.7
SLES	0.1934	0.732	218	15	800	2	50	154.7	35.1
SLEL	0.2903	1.099	145	10	800	3	76	232.3	52.8
SLFS	0.4026	1.542	218	15	600	3	76	241.5	54.8
SLFL	0.6036	2.285	145	10	600	4	101	362.2	82.3
SLGS	0.8374	3.17	218	15	600	4	101	502.5	114.1
SLGL	1.2559	4.754	145	10	600	6	152	753.5	171.1

<p>CAPACITY to 753 GPM (171 m³/h)</p>	<p>PRESSURE to 218 PSI (15 BAR)</p>	<p>VISCOSITY to 910,000 SSU (200,000 cSt)</p>	<p>TEMPERATURE to +300°F (+150°C)</p>
--	--	--	--

PORTING

- Complete range of hygienic clamp, screw, flange & industrial screw connections
- Tri-clamp, flanged, DIN, IMDA, NPT, BSP, etc.

SEALING

- Single mechanical
- Single mechanical with flush or quench
 - Standard Seal Faces: *C/SiC*
 - Standard O-rings & Cover Seals: *EPDM/FDA*
 - Optional Faces: *SiC/SiC*
 - Optional O-rings & Cover Seals: *FKM, Buna, Silicone, FFKM*
- Double mechanical with flush
 - Seal Faces: *C/SiC/SiC/C* or *SiC/SiC/SiC/C*
 - Standard O-rings & Cover Seals: *EPDM/FDA*
 - Optional Faces: *SiC/SiC*
 - Optional O-rings & Cover Seals: *FKM, Buna, Silicone, FFKM*

ROTOR & CASING OPTIONS

- 316L stainless steel pump casing with interior finished to Ra of 24µin (0.6µm).
- 316L stainless steel rotors
- 1.4435 low ferrite stainless steel optional
- Improved surface finishes & electropolishing optional
- Bi-wing rotors standard
 - No timing required
 - Preferred for large solids such as fruit pieces, nut kernels, cheese curds or meats
- Multilobe rotors optional
 - Provides reduced shear on shear sensitive fluids
 - Improved performance on thin liquids resulting in less pulsation at higher pressures

OPTIONAL COMPLIANCE CERTIFICATION DOCUMENTATION & PERFORMANCE TESTS

- Pump Performance
- Media Contact Elastomers
- Certified Documents
- General Compliance
- Seal Face
- ATEX & CE
- Media Contact Metallic Components
- Surface Finish
- Pump Assembly Inspection

TYPICAL APPLICATIONS

- Pharmaceutical
- Beverage
- Chemical
- Personal Care
- Dairy
- Foods
- Confectionary

BENEFITS OF MAINTENANCE KITS

- Everything you need in one place
- Reduce frequency of repairs
- Increase service life
- Increase uptime
- Save time & money
- Kits include exploded diagram & parts list



REBUILD VS. REPLACE

- Kits are designed to save time & money, making preventive maintenance easier & more cost-effective
- Pumps are designed & built to the highest standards, for long life & to be rebuilt instead of replaced when applicable
- Tool kits also available

VIKING PUMP®

VIKING PUMP, INC.
A Unit of IDEX Corporation
406 State Street
Cedar Falls, Iowa 50613 U.S.A.
vikingpump.com

CONTACT YOUR STOCKING DISTRIBUTOR TODAY

GLOBAL LEADER IN POSITIVE DISPLACEMENT PUMPING SOLUTIONS: Cedar Falls, Iowa, USA | Windsor, Ontario, Canada | Shannon, Ireland | Eastbourne, United Kingdom

IDEX

© Copyright 2020 Viking Pump, Inc. All Rights Reserved. Rev1120 | Form No. 1725